

# Прайс-лист ОМАКЕ

Представленная информация носит ознакомительный характер и ни при каких условиях не является публичной офертой. Для получения подробной информации о наличии и стоимости указанных товаров, пожалуйста, обращайтесь к нашим менеджерам по указанным контактам. Названия производителей или компаний, описания и фирменные наименования используются в справочных целях, а права на товарный знак являются исключительной собственностью владельца товарного знака и патента.

По вопросам продаж и поддержки обращайтесь:

Алматы (727)345-47-04  
Ангарск (3955)60-70-56  
Архангельск (8182)63-90-72  
Астрахань (8512)99-46-04  
Барнаул (3852)73-04-60  
Белгород (4722)40-23-64  
Благовещенск (4162)22-76-07  
Брянск (4832)59-03-52  
Владивосток (423)249-28-31  
Владикавказ (8672)28-90-48  
Владимир (4922)49-43-18  
Волгоград (844)278-03-48  
Вологда (8172)26-41-59  
Воронеж (473)204-51-73  
Екатеринбург (343)384-55-89

Иваново (4932)77-34-06  
Ижевск (3412)26-03-58  
Иркутск (395)279-98-46  
Казань (843)206-01-48  
Калининград (4012)72-03-81  
Калуга (4842)92-23-67  
Кемерово (3842)65-04-62  
Киров (8332)68-02-04  
Коломна (4966)23-41-49  
Кострома (4942)77-07-48  
Краснодар (861)203-40-90  
Красноярск (391)204-63-61  
Курск (4712)77-13-04  
Курган (3522)50-90-47  
Липецк (4742)52-20-81

Магнитогорск (3519)55-03-13  
Москва (495)268-04-70  
Мурманск (8152)59-64-93  
Набережные Челны (8552)20-53-41  
Нижний Новгород (831)429-08-12  
Новокузнецк (3843)20-46-81  
Ноябрьск (3496)41-32-12  
Новосибирск (383)227-86-73  
Омск (3812)21-46-40  
Орел (4862)44-53-42  
Оренбург (3532)37-68-04  
Пенза (8412)22-31-16  
Петрозаводск (8142)55-98-37  
Псков (8112)59-10-37  
Пермь (342)205-81-47

Ростов-на-Дону (863)308-18-15  
Рязань (4912)46-61-64  
Самара (846)206-03-16  
Санкт-Петербург (812)309-46-40  
Саратов (845)249-38-78  
Севастополь (8692)22-31-93  
Саранск (8342)22-96-24  
Симферополь (3652)67-13-56  
Смоленск (4812)29-41-54  
Сочи (862)225-72-31  
Ставрополь (8652)20-65-13  
Сургут (3462)77-98-35  
Сыктывкар (8212)25-95-17  
Тамбов (4752)50-40-97  
Тверь (4822)63-31-35

Тольятти (8482)63-91-07  
Томск (3822)98-41-53  
Тула (4872)33-79-87  
Тюмень (3452)66-21-18  
Ульяновск (8422)24-23-59  
Улан-Удэ (3012)59-97-51  
Уфа (347)229-48-12  
Хабаровск (4212)92-98-04  
Чебоксары (8352)28-53-07  
Челябинск (351)202-03-61  
Череповец (8202)49-02-64  
Чита (3022)38-34-83  
Якутск (4112)23-90-97  
Ярославль (4852)69-52-93

Россия +7(495)268-04-70

Казахстан +7(727)345-47-04

Беларусь +375-257-127-884

Узбекистан +998(71)205-18-59

Киргизия +996(312)96-26-47

эл.почта: [oek@nt-rt.ru](mailto:oek@nt-rt.ru) || сайт: <https://omake.nt-rt.ru>

# İÇİNDEKİLER / INDEX



## KAFE & BAR / CAFE & BAR

- 06-21 BAR BLENDERLERİ / BAR BLENDERS  
22 KUMDA KAHVE MAKİNELERİ / SAND COFFEE MACHINE  
23 ÇAY MAKİNELERİ / TEA MACHINES  
24-39 WAFFLE MAKİNELERİ / WAFFLE MAKERS  
40-42 POFFERTJES MAKİNELERİ / POFFERTJES MAKERS  
43-48 KREP MAKİNELERİ / CREPE MAKERS  
49-54 PANKEK MAKİNELERİ / PANCAKE MAKERS  
55-59 ŞERBETLİK MAKİNELERİ / JUICE DISPENSER  
60-63 TOST MAKİNELERİ / TOASTERS



## HAZIRLIK / DYNAMIC PREP

- 65-66 SEBZE PARÇALAMA MAKİNELERİ / VEGETABLE CUTTERS  
67 HUMUS MAKİNELERİ / HUMMUS MACHINES  
68 TABAK KAPATMA MAKİNESİ / MEAL SEALING  
69 SET ÜSTÜ MİKSERLER / STAND MIXERS  
70 HAMUR AÇMA MAKİNESİ / DOUGH ROLLER MACHINES



## PIŞİRME / COOK

- 72-76 IZGARALAR / GRILLS  
77 BURGER / BURGER  
78 MAKARNA HAŞLAMA / PASTA COOKER  
79-82 FRİTÖZLER / FRYERS  
83-85 OCAKLAR / COOKERS  
86-91 İNDÜKSİYON OCAKLAR / INDUCTION COOKERS  
92 SOSİS KIZARTMA / HOT DOG GRILL  
93 SOSİS ISITMA / HOT DOG WARMER  
94 SOSİS HAŞLAMA / HOT DOG BOILED  
95 SOSİS DİNLENDİRME MAKİNESİ / HOT DOG DISPLAY CASE  
96 SALAMANDER / SALAMENDER  
97 BENMARİ / BAINMARIE  
98 PATATES DİNLENDİRME / CHIPS SCUTTLE UNIT  
99 EKMEK KIZARTMA / CONVEYOR TOASTER  
100-101 MANUEL LOKMA MAKİNESİ / MANUAL DOUGHNUT MACHINE



## FIRIN / OVEN

- 103-105 ELEKTRİKLİ PİZZA FIRINLARI / ELECTRIC PIZZA OVENS  
106-107 KUMPIR FIRINLARI / POTATO BAKING OVENS



## YIKAMA GRUBU / WASHING GROUP

- 110 DİZDEN KUMANDALI EL YIKAMALAR / KNEE OPERATED HAND WASHES  
111 AYAKTAN KUMANDALI EL YIKAMALAR / FOOT OPERATED HAND WASHES

# Omk.WFL01.E22.0201.Z5F

**Fiş Tipi**  
Plug Type

0	Fişsiz	Without Plug
F	Avrupa	Europe
G	İngiliz	England
E	Fransa	France
H	İsrail	Israel

**Voltaj**  
Voltage

	Monophase	Threephase
1	110	190
2	110-115-120	190-200-208
3	125	216
4	220	380
5	220-230-240	380-400-415
6	240	415
7	250	440

**Elektrik Tipi**  
Electric Type

Z	Monophase 50/60
Y	Monophase 50
V	Monophase 60
U	Threephase 50/60
T	Threephase 50
S	Threephase 60

**Ürün Kodu**  
Product Code

**Kontrolör Tipi**  
Controller Type

1	Manuel	Manual
2	Timer	Timer
5	Dijital	Digital

**Cihaz Sayısı**  
Device Quantity

1	Tekli	Single
2	Çiftli	Double
3	Üçlü	Triple
4	Dörtlü	Quad

**Enerji Tipi**  
Energy Type

E	Elektrik	Electric
I	İndüksiyon	Induction
N	Doğalgaz	NG
L	LPG	LPG
O	Nötr	Notr

**Ürün Grubu**  
Product Group

**Üretici Kodu**  
Manufacture Code





# KAFE & BAR

## CAFE & BAR



**BAR BLENDERLERİ**  
BAR BLENDERS



**KUMDA KAHVE**  
SAND COFFEE MACHINE



**ÇAY MAKİNELERİ**  
TEA MACHINES



**WAFFLE MAKİNELERİ**  
WAFFLE MAKERS



**POFFERTJES MAKİNELERİ**  
POFFERTJES MAKERS



**KREP MAKİNELERİ**  
CREPE MAKERS



**PANKEK MAKİNELERİ**  
PANCAKE MAKERS



**ŞERBETLİK MAKİNELERİ**  
JUICE DISPENSER



**TOST MAKİNELERİ**  
TOASTERS

## BAR BLENDERLERİ

BAR BLENDERS

### TR

Türkiye'nin ilk yerli üretim Bar Blenderi olan OMAKE bar blenderleri ile işletmenize güç katın.

Omake bar blenderleri güçlü motoru ve güncel tasarımı ile yoğun çalışma şartlarında çok sayıda içecek hazırlamanıza yardımcı olur. 3 veya 2 Lt sùrahi kapasitesiyle yüksek miktarda ürünü tek seferde parçalayıp karıştırabilirsiniz.



### EN

Omake brings power of a high quality bar blender to your facility with first Bar Blender series manufactured in Turkey. The Omake Bar Blenders has your back with it is strong motor and well designed engineering when it comes to heavy-duty blenders, serving dozens of drinks per day. Chop, mix, shred large loads easily with it's 3 or 2 Lt jug capacity.

### TR

- Manuel ve dijital model seçeneđi
- Karıştırma ve parçalama özelliđi
- Max 25.000 RPM çalışma hızı
- Kapak sensör seçeneđi
- 3 veya 2 Lt sùrahi kapasitesi
- Hız kontrolü
- Buz kırma özelliđi
- ABS gövde
- Gıda ile temasa uygun polikarbon sùrahi

### EN

- Manual and digital model option
- Mix and pulse option
- Max. 25.000 RPM working speed
- Lid sensor option
- 3 or 2 Lt jug capacity
- Speed control
- Ice crushing feature
- ABS Body
- Polycarbonate container suitable for food contact

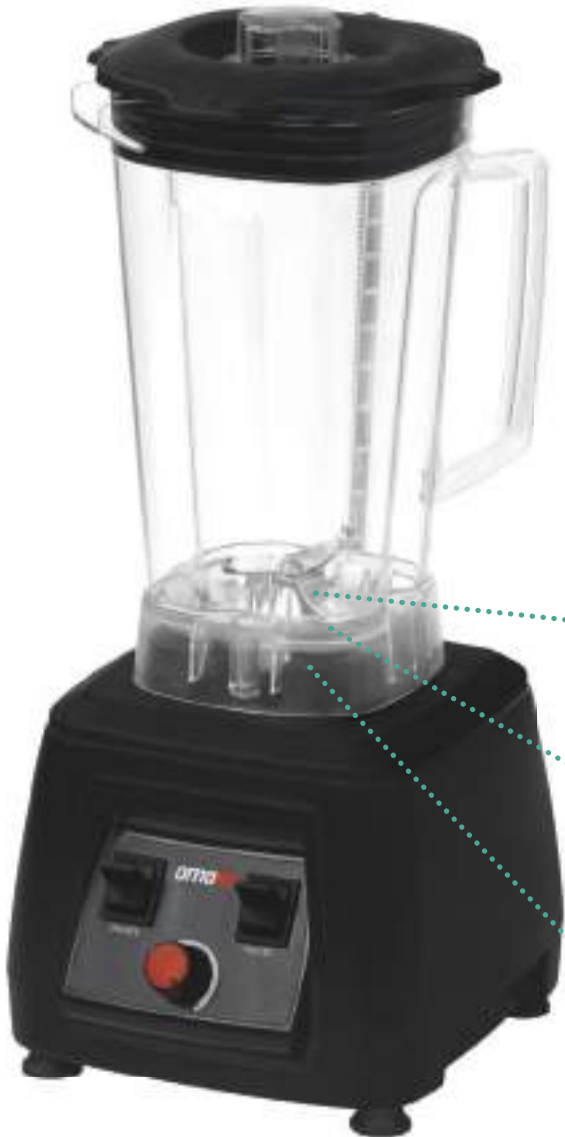

Paslanmaz çelik bıçaklar  
Heavy-duty stainless steel blade

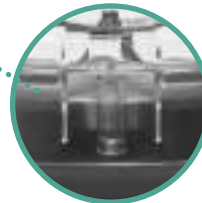

Paslanmaz çelik alt dişli grubu  
Long lasting coupling system  
ensures durability at heavy duty  
use



Kolay temizlenebilir, kolay  
sökülebilir ve tek parça sùrahi pedi  
One piece removable jar pad  
design makes cleanup quick and  
easy

**BAR BLENDERLERİ**  
BAR BLENDERS



**Omk.BLE01.E11.0101.Z5F**

- MANUEL**  
MANUAL
- KAPAK SENSÖRLÜ**  
WITH LID SENSOR
- 3 LT KAPASİTE**  
3 LT CAPACITY



**Omk.BLE01.E11.0103.Z5F**

- MANUEL**  
MANUAL
- KAPAK SENSÖRLÜ**  
WITH LID SENSOR
- 3 LT KAPASİTE**  
3 LT CAPACITY



**Omk.BLE01.E11.0104.Z5F**

- MANUEL**  
MANUAL
- KAPAK SENSÖRLÜ**  
WITH LID SENSOR
- 3 LT KAPASİTE**  
3 LT CAPACITY

KOD / CODE	RENK / COLOR						
Omk.BLE01.E11.0101.Z5F	● Siyah / Black	210x240x490 mm	4,7 Kg	230 / 50-60 V/HZ - 2,2 kW	250x270x500 mm	5,4 Kg	200,51
Omk.BLE01.E11.0103.Z5F	● Kırmızı / Red	210x240x490 mm	4,7 Kg	230 / 50-60 V/HZ - 2,2 kW	250x270x500 mm	5,4 Kg	200,51
Omk.BLE01.E11.0104.Z5F	● Mavi / Blue	210x240x490 mm	4,7 Kg	230 / 50-60 V/HZ - 2,2 kW	250x270x500 mm	5,4 Kg	200,51



**MANUEL**  
MANUAL



Omk.BLE01.E15.0101.Z5F

- DİJİTAL  
DIGITAL
- KAPAK SENSÖRLÜ  
WITH LID SENSOR
- 3 LT KAPASİTE  
3 LT CAPACITY



Omk.BLE01.E15.0103.Z5F

- DİJİTAL  
DIGITAL
- KAPAK SENSÖRLÜ  
WITH LID SENSOR
- 3 LT KAPASİTE  
3 LT CAPACITY



Omk.BLE01.E15.0104.Z5F

- DİJİTAL  
DIGITAL
- KAPAK SENSÖRLÜ  
WITH LID SENSOR
- 3 LT KAPASİTE  
3 LT CAPACITY

KOD / CODE	RENK / COLOR						
Omk.BLE01.E15.0101.Z5F	● Siyah / Black	210x240x490 mm	4,7 Kg	230 / 50-60 V/HZ - 2,2 kW	250x270x500 mm	5,4 Kg	219,78
Omk.BLE01.E15.0103.Z5F	● Kırmızı / Red	210x240x490 mm	4,7 Kg	230 / 50-60 V/HZ - 2,2 kW	250x270x500 mm	5,4 Kg	219,78
Omk.BLE01.E15.0104.Z5F	● Mavi / Blue	210x240x490 mm	4,7 Kg	230 / 50-60 V/HZ - 2,2 kW	250x270x500 mm	5,4 Kg	219,78



DİJİTAL  
DIGITAL

**BAR BLENDERLERİ**  
BAR BLENDERS



**Omk.BLE01.E11.0201.Z5F**

- MANUEL**  
MANUAL
- KAPAK SENSÖRSÜZ**  
WITHOUT LID SENSOR
- 3 LT KAPASİTE**  
3 LT CAPACITY



**Omk.BLE01.E11.0203.Z5F**

- MANUEL**  
MANUAL
- KAPAK SENSÖRSÜZ**  
WITHOUT LID SENSOR
- 3 LT KAPASİTE**  
3 LT CAPACITY



**Omk.BLE01.E11.0204.Z5F**

- MANUEL**  
MANUAL
- KAPAK SENSÖRSÜZ**  
WITHOUT LID SENSOR
- 3 LT KAPASİTE**  
3 LT CAPACITY

KOD / CODE	RENK / COLOR						
Omk.BLE01.E11.0201.Z5F	● Siyah / Black	210x240x490 mm	4,7 Kg	230 / 50-60 V/HZ - 2,2 kW	250x270x500 mm	5,4 Kg	194,75
Omk.BLE01.E11.0203.Z5F	● Kırmızı / Red	210x240x490 mm	4,7 Kg	230 / 50-60 V/HZ - 2,2 kW	250x270x500 mm	5,4 Kg	194,75
Omk.BLE01.E11.0204.Z5F	● Mavi / Blue	210x240x490 mm	4,7 Kg	230 / 50-60 V/HZ - 2,2 kW	250x270x500 mm	5,4 Kg	194,75



**MANUEL**  
MANUAL



Omk.BLE01.E15.0201.Z5F

- DİJİTAL  
DIGITAL
- KAPAK SENSÖRSÜZ  
WITHOUT LID SENSOR
- 3 LT KAPASİTE  
3 LT CAPACITY



Omk.BLE01.E15.0203.Z5F

- DİJİTAL  
DIGITAL
- KAPAK SENSÖRSÜZ  
WITHOUT LID SENSOR
- 3 LT KAPASİTE  
3 LT CAPACITY



Omk.BLE01.E15.0204.Z5F

- DİJİTAL  
DIGITAL
- KAPAK SENSÖRSÜZ  
WITHOUT LID SENSOR
- 3 LT KAPASİTE  
3 LT CAPACITY

KOD / CODE	RENK / COLOR						
Omk.BLE01.E15.0201.Z5F	● Siyah / Black	210x240x490 mm	4,7 Kg	230 / 50-60 V/Hz - 2,2 kW	250x270x500 mm	5,4 Kg	213,62
Omk.BLE01.E15.0203.Z5F	● Kırmızı / Red	210x240x490 mm	4,7 Kg	230 / 50-60 V/Hz - 2,2 kW	250x270x500 mm	5,4 Kg	213,62
Omk.BLE01.E15.0204.Z5F	● Mavi / Blue	210x240x490 mm	4,7 Kg	230 / 50-60 V/Hz - 2,2 kW	250x270x500 mm	5,4 Kg	213,62





DİJİTAL  
DIGITAL

**BAR BLENDERLERİ**  
BAR BLENDERS





**Omk.BLE02.E11.0201 .Z5F**

-  **MANUEL**  
MANUAL
-  **KAPAK SENSÖRSÜZ**  
WITHOUT LID SENSOR
-  **3 LT KAPASİTE**  
3 LT CAPACITY





**Omk.BLE02.E11.0203 .Z5F**

-  **MANUEL**  
MANUAL
-  **KAPAK SENSÖRSÜZ**  
WITHOUT LID SENSOR
-  **3 LT KAPASİTE**  
3 LT CAPACITY



**Omk.BLE02.E11.0204.Z5F**

-  **MANUEL**  
MANUAL
-  **KAPAK SENSÖRSÜZ**  
WITHOUT LID SENSOR
-  **3 LT KAPASİTE**  
3 LT CAPACITY

KOD / CODE	RENK / COLOR						
Omk.BLE02.E11.0201.Z5F	● Siyah / Black	210x240x490 mm	4,7 Kg	20 / 50-60 V/HZ - 2,2 kW	250x270x500 mm	5,4 Kg	194,05
Omk.BLE02.E11.0203.Z5F	● Kırmızı / Red	210x240x490 mm	4,7 Kg	230 / 50-60 V/HZ - 2,2 kW	250x270x500 mm	5,4 Kg	194,05
Omk.BLE02.E11.0204.Z5F	● Mavi / Blue	210x240x490 mm	4,7 Kg	230 / 50-60 V/HZ - 2,2 kW	250x270x500 mm	5,4 Kg	194,05



 **MANUEL**  
MANUAL



Omk.BLE02.E15.0201.Z5F

- DİJİTAL  
DIGITAL
- KAPAK SENSÖRSÜZ  
WITHOUT LID SENSOR
- 3 LT KAPASİTE  
3 LT CAPACITY



Omk.BLE02.E15.0203.Z5F

- DİJİTAL  
DIGITAL
- KAPAK SENSÖRSÜZ  
WITHOUT LID SENSOR
- 3 LT KAPASİTE  
3 LT CAPACITY



Omk.BLE02.E15.0204.Z5F

- DİJİTAL  
DIGITAL
- KAPAK SENSÖRSÜZ  
WITHOUT LID SENSOR
- 3 LT KAPASİTE  
3 LT CAPACITY

KOD / CODE	RENK / COLOR						€
Omk.BLE02.E15.0201.Z5F	● Siyah / Black	210x240x490 mm	4,7 Kg	230 / 50-60 V/HZ - 2,2 kW	250x270x500 mm	5,4 Kg	212,89
Omk.BLE02.E15.0203.Z5F	● Kırmızı / Red	210x240x490 mm	4,7 Kg	230 / 50-60 V/HZ - 2,2 kW	250x270x500 mm	5,4 Kg	212,89
Omk.BLE02.E15.0204.Z5F	● Mavi / Blue	210x240x490 mm	4,7 Kg	230 / 50-60 V/HZ - 2,2 kW	250x270x500 mm	5,4 Kg	212,89





DİJİTAL  
DIGITAL

**BAR BLENDERLERİ**  
BAR BLENDERS





**Omk.BLE05.E11.0201.Z5F**

-  **MANUEL**  
MANUAL
-  **KAPAK SENSÖRSÜZ**  
WITHOUT LID SENSOR
-  **2 LT KAPASİTE**  
2 LT CAPACITY





**Omk.BLE05.E11.0203.Z5F**

-  **MANUEL**  
MANUAL
-  **KAPAK SENSÖRSÜZ**  
WITHOUT LID SENSOR
-  **2 LT KAPASİTE**  
2 LT CAPACITY



**Omk.BLE05.E11.0204.Z5F**

-  **MANUEL**  
MANUAL
-  **KAPAK SENSÖRSÜZ**  
WITHOUT LID SENSOR
-  **2 LT KAPASİTE**  
2 LT CAPACITY

KOD / CODE	RENK / COLOR						
Omk.BLE05.E11.0201.Z5F	● Siyah / Black	210x240x430 mm	4,5 Kg	230 / 50-60 V/HZ - 2,2 kW	250x270x440 mm	5,1 Kg	191,19
Omk.BLE05.E11.0203.Z5F	● Kırmızı / Red	210x240x430 mm	4,5 Kg	230 / 50-60 V/HZ - 2,2 kW	250x270x440 mm	5,1 Kg	191,19
Omk.BLE05.E11.0204.Z5F	● Mavi / Blue	210x240x430 mm	4,5 Kg	230 / 50-60 V/HZ - 2,2 kW	250x270x440 mm	5,1 Kg	191,19



 **MANUEL**  
MANUAL



Omk.BLE05.E15.0201.Z5F

- DİJİTAL  
DIGITAL
- KAPAK SENSÖRSÜZ  
WITHOUT LID SENSOR
- 2 LT KAPASİTE  
2 LT CAPACITY



Omk.BLE05.E15.0203.Z5F

- DİJİTAL  
DIGITAL
- KAPAK SENSÖRSÜZ  
WITHOUT LID SENSOR
- 2 LT KAPASİTE  
2 LT CAPACITY



Omk.BLE05.E15.0204.Z5F

- DİJİTAL  
DIGITAL
- KAPAK SENSÖRSÜZ  
WITHOUT LID SENSOR
- 2 LT KAPASİTE  
2 LT CAPACITY

KOD / CODE	RENK / COLOR						€
Omk.BLE05.E15.0201.Z5F	● Siyah / Black	210x240x430 mm	4,5 Kg	230 / 50-60 V/HZ - 2,2 kW	250x270x440 mm	5,1 Kg	209,87
Omk.BLE05.E15.0203.Z5F	● Kırmızı / Red	210x240x430 mm	4,5 Kg	230 / 50-60 V/HZ - 2,2 kW	250x270x440 mm	5,1 Kg	209,87
Omk.BLE05.E15.0204.Z5F	● Mavi / Blue	210x240x430 mm	4,5 Kg	230 / 50-60 V/HZ - 2,2 kW	250x270x440 mm	5,1 Kg	209,87



DİJİTAL  
DIGITAL

**BAR BLENDERLERİ**  
BAR BLENDERS



**Omk.BLE11.E11.0201.Z5F**

- MANUEL**  
MANUAL
- KAPAK SENSÖRSÜZ**  
WITHOUT LID SENSOR
- 3 LT KAPASİTE**  
3 LT CAPACITY



**Omk.BLE11.E11.0203.Z5F**

- MANUEL**  
MANUAL
- KAPAK SENSÖRSÜZ**  
WITHOUT LID SENSOR
- 3 LT KAPASİTE**  
3 LT CAPACITY



**Omk.BLE11.E11.0204.Z5F**

- MANUEL**  
MANUAL
- KAPAK SENSÖRSÜZ**  
WITHOUT LID SENSOR
- 3 LT KAPASİTE**  
3 LT CAPACITY

KOD / CODE	RENK / COLOR						
Omk.BLE11.E11.0201.Z5F	● Siyah / Black	215x225x545 mm	4,6 Kg	230 / 50-60 V/HZ - 2,2 kW	230x230x510 mm	5,0 Kg	200,64
Omk.BLE11.E11.0203.Z5F	● Kırmızı / Red	215x225x545 mm	4,6 Kg	230 / 50-60 V/HZ - 2,2 kW	230x230x510 mm	5,0 Kg	200,64
Omk.BLE11.E11.0204.Z5F	● Mavi / Blue	215x225x545 mm	4,6 Kg	230 / 50-60 V/HZ - 2,2 kW	230x230x510 mm	5,0 Kg	200,64



**MANUEL**  
MANUAL



**Omk.BLE11.E15.0201.Z5F**

- DİJİTAL**  
DIGITAL
- KAPAK SENSÖRSÜZ**  
WITHOUT LID SENSOR
- 3 LT KAPASİTE**  
3 LT CAPACITY



**Omk.BLE11.E15.0203.Z5F**

- DİJİTAL**  
DIGITAL
- KAPAK SENSÖRSÜZ**  
WITHOUT LID SENSOR
- 3 LT KAPASİTE**  
3 LT CAPACITY



**Omk.BLE11.E15.0204.Z5F**

- DİJİTAL**  
DIGITAL
- KAPAK SENSÖRSÜZ**  
WITHOUT LID SENSOR
- 3 LT KAPASİTE**  
3 LT CAPACITY

KOD / CODE	RENK / COLOR						€
Omk.BLE11.E15.0201.Z5F	● Siyah / Black	215x225x545 mm	4,6 Kg	230 / 50-60 V/HZ - 2,2 kW	230x230x510 mm	5,0 Kg	220,39
Omk.BLE11.E15.0203.Z5F	● Kırmızı / Red	215x225x545 mm	4,6 Kg	230 / 50-60 V/HZ - 2,2 kW	230x230x510 mm	5,0 Kg	220,39
Omk.BLE11.E15.0204.Z5F	● Mavi / Blue	215x225x545 mm	4,6 Kg	230 / 50-60 V/HZ - 2,2 kW	230x230x510 mm	5,0 Kg	220,39



**DİJİTAL**  
DIGITAL

**BAR BLENDERLERİ**  
BAR BLENDERS



**Omk.BLE12.E11.0201.Z5F**

- MANUEL**  
MANUAL
- KAPAK SENSÖRSÜZ**  
WITHOUT LID SENSOR
- 3 LT KAPASİTE**  
3 LT CAPACITY



**Omk.BLE12.E11.0203.Z5F**

- MANUEL**  
MANUAL
- KAPAK SENSÖRSÜZ**  
WITHOUT LID SENSOR
- 3 LT KAPASİTE**  
3 LT CAPACITY



**Omk.BLE12.E11.0204.Z5F**

- MANUEL**  
MANUAL
- KAPAK SENSÖRSÜZ**  
WITHOUT LID SENSOR
- 3 LT KAPASİTE**  
3 LT CAPACITY

KOD / CODE	RENK / COLOR						
Omk.BLE12.E11.0201.Z5F	●Siyah / Black	215x225x545 mm	4,6 Kg	230 / 50-60 V/HZ - 2,2 kW	230x230x510 mm	5,0 Kg	199,99
Omk.BLE12.E11.0203.Z5F	●Kırmızı / Red	215x225x545 mm	4,6 Kg	230 / 50-60 V/HZ - 2,2 kW	230x230x510 mm	5,0 Kg	199,99
Omk.BLE12.E11.0204.Z5F	●Mavi / Blue	215x225x545 mm	4,6 Kg	230 / 50-60 V/HZ - 2,2 kW	230x230x510 mm	5,0 Kg	199,99



**MANUEL**  
MANUAL



Omk.BLE12.E15.0201.Z5F

- DİJİTAL  
DIGITAL
- KAPAK SENSÖRSÜZ  
WITHOUT LID SENSOR
- 3 LT KAPASİTE  
3 LT CAPACITY



Omk.BLE12.E15.0203.Z5F

- DİJİTAL  
DIGITAL
- KAPAK SENSÖRSÜZ  
WITHOUT LID SENSOR
- 3 LT KAPASİTE  
3 LT CAPACITY



Omk.BLE12.E15.0204.Z5F

- DİJİTAL  
DIGITAL
- KAPAK SENSÖRSÜZ  
WITHOUT LID SENSOR
- 3 LT KAPASİTE  
3 LT CAPACITY

KOD / CODE	RENK / COLOR						
Omk.BLE12.E15.0201.Z5F	● Siyah / Black	215x225x545 mm	4,6 Kg	230 / 50-60 V/HZ - 2,2 kW	230x230x510 mm	5,0 Kg	219,76
Omk.BLE12.E15.0203.Z5F	● Kırmızı / Red	215x225x545 mm	4,6 Kg	230 / 50-60 V/HZ - 2,2 kW	230x230x510 mm	5,0 Kg	219,76
Omk.BLE12.E15.0204.Z5F	● Mavi / Blue	215x225x545 mm	4,6 Kg	230 / 50-60 V/HZ - 2,2 kW	230x230x510 mm	5,0 Kg	219,76





DİJİTAL  
DIGITAL

**BAR BLENDERLERİ**  
BAR BLENDERS





**Omk.BLE15.E11.0201.Z5F**

-  **MANUEL**  
MANUAL
-  **KAPAK SENSÖRSÜZ**  
WITHOUT LID SENSOR
-  **2 LT KAPASİTE**  
2 LT CAPACITY





**Omk.BLE15.E11.0203.Z5F**

-  **MANUEL**  
MANUAL
-  **KAPAK SENSÖRSÜZ**  
WITHOUT LID SENSOR
-  **2 LT KAPASİTE**  
2 LT CAPACITY



**Omk.BLE15.E11.0204.Z5F**

-  **MANUEL**  
MANUAL
-  **KAPAK SENSÖRSÜZ**  
WITHOUT LID SENSOR
-  **2 LT KAPASİTE**  
2 LT CAPACITY

KOD / CODE	RENK / COLOR						
Omk.BLE15.E11.0201.Z5F	● Siyah / Black	215x225x485 mm	4,2 Kg	230 / 50-60 V/HZ - 2,2 kW	230x230x500 mm	4,7 Kg	198,69
Omk.BLE15.E11.0203.Z5F	● Kırmızı / Red	215x225x485 mm	4,2 Kg	230 / 50-60 V/HZ - 2,2 kW	230x230x500 mm	4,7 Kg	198,69
Omk.BLE15.E11.0204.Z5F	● Mavi / Blue	215x225x485 mm	4,2 Kg	230 / 50-60 V/HZ - 2,2 kW	230x230x500 mm	4,7 Kg	198,69



 **MANUEL**  
MANUAL



**Omk.BLE15.E15.0201.Z5F**

- DİJİTAL**  
DIGITAL
- KAPAK SENSÖRSÜZ**  
WITHOUT LID SENSOR
- 2 LT KAPASİTE**  
2 LT CAPACITY



**Omk.BLE15.E15.0203.Z5F**

- DİJİTAL**  
DIGITAL
- KAPAK SENSÖRSÜZ**  
WITHOUT LID SENSOR
- 2 LT KAPASİTE**  
2 LT CAPACITY



**Omk.BLE15.E15.0204.Z5F**

- DİJİTAL**  
DIGITAL
- KAPAK SENSÖRSÜZ**  
WITHOUT LID SENSOR
- 2 LT KAPASİTE**  
2 LT CAPACITY

KOD / CODE	RENK / COLOR						
Omk.BLE15.E15.0201.Z5F	● Siyah / Black	215x225x485 mm	4,2 Kg	230 / 50-60 V/HZ - 2,2 kW	230x230x500 mm	4,7 Kg	218,38
Omk.BLE15.E15.0203.Z5F	● Kırmızı / Red	215x225x485 mm	4,2 Kg	230 / 50-60 V/HZ - 2,2 kW	230x230x500 mm	4,7 Kg	218,38
Omk.BLE15.E15.0204.Z5F	● Mavi / Blue	215x225x485 mm	4,2 Kg	230 / 50-60 V/HZ - 2,2 kW	230x230x500 mm	4,7 Kg	218,38





**DİJİTAL**  
DIGITAL

**SESSİZ BLENDER**  
SILENCE BLENDERS





**Omk.BLE41.E15.0201.Z5F**

-  **DİJİTAL**  
DIGITAL
-  **KAPAK SENSÖRSÜZ**  
WITHOUT LID SENSOR
-  **2 LT KAPASİTE**  
2 LT CAPACITY





**Omk.BLE41.E15.0203.Z5F**

-  **DİJİTAL**  
DIGITAL
-  **KAPAK SENSÖRSÜZ**  
WITHOUT LID SENSOR
-  **2 LT KAPASİTE**  
2 LT CAPACITY



**Omk.BLE41.E15.0204.Z5F**

-  **DİJİTAL**  
DIGITAL
-  **KAPAK SENSÖRSÜZ**  
WITHOUT LID SENSOR
-  **2 LT KAPASİTE**  
2 LT CAPACITY

KOD / CODE	RENK / COLOR						
Omk.BLE41.E15.0201.Z5F	● Siyah / Black	245x260x470 mm	7,0 Kg	230 / 50-60 V/HZ - 2,2 kW	260x270x480 mm	8,0 Kg	561,81
Omk.BLE41.E15.0203.Z5F	● Kırmızı / Red	245x260x470 mm	7,0 Kg	230 / 50-60 V/HZ - 2,2 kW	260x270x480 mm	8,0 Kg	561,81
Omk.BLE41.E15.0204.Z5F	● Mavi / Blue	245x260x470 mm	7,0 Kg	230 / 50-60 V/HZ - 2,2 kW	260x270x480 mm	8,0 Kg	561,81



**DİJİTAL**  
DIGITAL



KOD / CODE						
Omk.KKM01.E11.0001.Z5F	365x310x180 mm	4,0 kg	230 / 50-60 V/Hz - 1,0 kW	380x350x185 mm	4,5 kg	121,45

**TR**

- Elektrikli model
- Özel kumu sayesinde verimli ısıtma
- Paslanmaz çelik gövde
- Ergonomik dizayn
- Sanayi tipi
- Farklı sıcaklık ayarlarında çalıştırma

**EN**

- Electric model option
- Efficient heating regarding to its special sand
- Stainless steel body
- Ergonomic design
- Industrial type
- Operation at different temperature setting





**Omk.CAY01.E11.0023.Z5F**

- MANUEL  
MANUAL
- 23 LT KAPASİTE  
23 LT CAPACITY
- ŞAMANDIRALI / 2 DEMLİKLİ  
WITH FLOAT / 2 POT



**Omk.CAY01.E11.0040.Z5F**

- MANUEL  
MANUAL
- 40 LT KAPASİTE  
40 LT CAPACITY
- ŞAMANDIRALI / 3 DEMLİKLİ  
WITH FLOAT / 3 POT

KOD / CODE						€
Omk.CAY01.E11.0023.Z5F	340x510x600 mm	12,5 kg	230 / 50-60 V/Hz - 2,5 kW	360x560x470 mm	13,5 kg	381,50
Omk.CAY01.E11.0040.Z5F	400x550x710 mm	16,0 kg	230 / 50-60 V/Hz - 3 kW	360x480x560 mm	17,0 kg	474,56



**Omk.CAY11.E11.0023.Z5F**

- MANUEL  
MANUAL
- 23 LT KAPASİTE  
23 LT CAPACITY
- ŞAMANDIRALI  
WITH FLOAT



**Omk.CAY11.E11.0040.Z5F**

- MANUEL  
MANUAL
- 40 LT KAPASİTE  
40 LT CAPACITY
- ŞAMANDIRALI  
WITH FLOAT

KOD / CODE						€
Omk.CAY11.E11.0023.Z5F	340x510x425 mm	13,5 kg	230 / 50-60 V/Hz - 2,5 kW	360x480x560 mm	14,5 kg	334,88
Omk.CAY11.E11.0040.Z5F	340x510x535 mm	16,0 kg	230 / 50-60 V/Hz - 3 kW	360x480x560 mm	17,0 kg	369,10



**Omk.CAY11.E11.0023.Z5F**

- DİJİTAL  
DIGITAL
- 23 LT KAPASİTE  
23 LT CAPACITY
- ŞAMANDIRALI  
WITH FLOAT



**Omk.CAY11.E11.0040.Z5F**

- DİJİTAL  
DIGITAL
- 40 LT KAPASİTE  
40 LT CAPACITY
- ŞAMANDIRALI  
WITH FLOAT

KOD / CODE						€
Omk.CAY01.E15.0023.Z5F	340x510x600 mm	12,5 kg	230 / 50-60 V/Hz - 2,5 kW	360x560x470 mm	13,5 kg	422,59
Omk.CAY01.E15.0040.Z5F	400x550x710 mm	16,0 kg	230 / 50-60 V/Hz - 3 kW	360x480x560 mm	17,0 kg	526,47

## YUVARLAK WAFFLE MAKİNELERİ

ROUND WAFFLE MAKERS

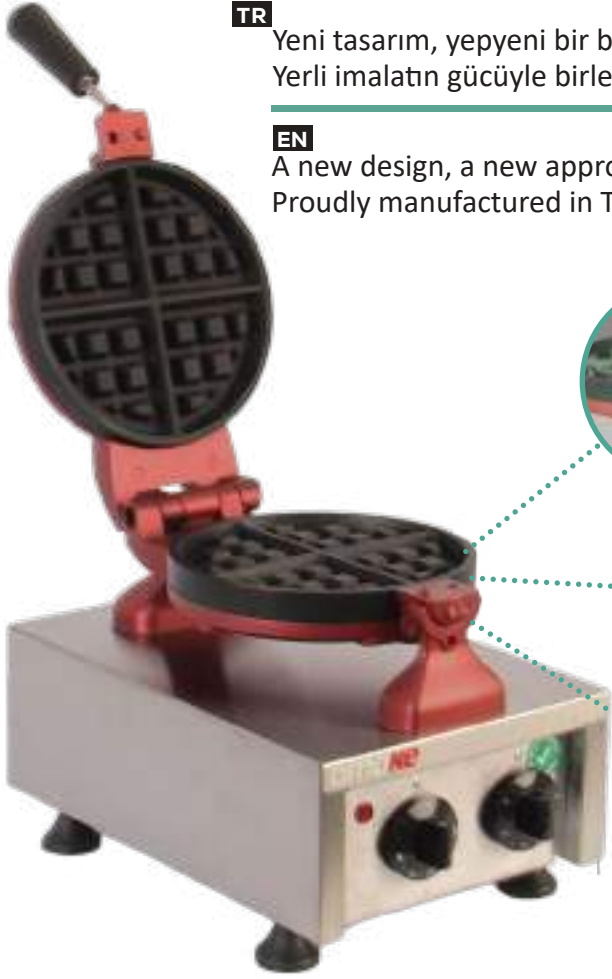

**TR**

Yeni tasarım, yepyeni bir bakış açısı.  
Yerli imalatın gücüyle birleşti.

**EN**

A new design, a new approach to waffle baking.  
Proudly manufactured in Turkey.



Kolay değiştirilebilir pişirme kalıpları  
Easy to change baking plates  
provides efficient operation

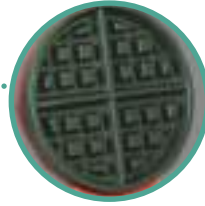

Teflon kaplı yapışmaz pişirme yüzeyi  
Teflon coated non-stick baking plate



Alüminyum teflon kaplamalı üst gövde  
Aluminium teflon coated top body



**TR**

- Tekli ve çiftli model seçeneği
- Mekanik zamanlayıcı model
- Teflon kaplı yapışmaz pişirme yüzeyi ve üst gövde
- Kolay değiştirilebilir teflon pişirme kalıpları
- Farklı şekillerde pişirme kalıpları
- Paslanmaz çelik gömülü ısıtıcılar ile hassas sıcaklık kontrolü
- Farklı sıcaklık ayarlarında çalıştırma
- Seri pişirmelerde yüksek performans
- Gösterge ve sinyal lambaları
- Paslanmaz çelik alt gövde
- Gıda ile temasa uygun pişirme kalıpları ve gövde

**EN**

- Single and double model options
- Mechanic timer model.
- Teflon coated Non-Stick baking plate and top body
- Easy to change teflon coated baking plates
- Different shaped baking plates feature
- Stainless steel embedded heating element for precise temperature control
- Operation with desired heating temperature
- High performance during dynamic operation
- Power ON and Ready-to-Bake LED indicators
- Stainless steel frame body
- Baking plates and body suitable for food contact

**YUVARLAK WAFFLE MAKİNELERİ**  
ROUND WAFFLE MAKERS









**Omk.WFL01.E12.0101.Z5F**

 **MANUEL TIMER**  
MANUAL WITH TIMER



**Omk.WFL01.E12.0201.Z5F**

 **MANUEL TIMER**  
MANUAL WITH TIMER

KOD / CODE						
Omk.WFL01.E12.0101.Z5F	225x400x250 mm	7,0 kg	230 / 50-60 V/HZ - 1,3 kW	250x440x280 mm	8.0 Kg	226,81
Omk.WFL01.E12.0201.Z5F	225x400x250 mm	7,0 kg	230 / 50-60 V/HZ - 1,3 kW	250x440x280 mm	8.0 Kg	226,81







**Omk.WFL01.E22.0101.Z5F**

 **MANUEL TIMER**  
MANUAL WITH TIMER



**Omk.WFL01.E22.0201.Z5F**

 **MANUEL TIMER**  
MANUAL WITH TIMER

KOD / CODE						
Omk.WFL01.E22.0101.Z5F	450x400x250 mm	13,5 kg	230 / 50-60 V/HZ - 2,6 kW	470x440x280 mm	14,5 kg	423,57
Omk.WFL01.E22.0201.Z5F	450x400x250 mm	14,5 kg	230 / 50-60 V/HZ - 2,6 kW	470x440x280 mm	15,5 kg	423,57

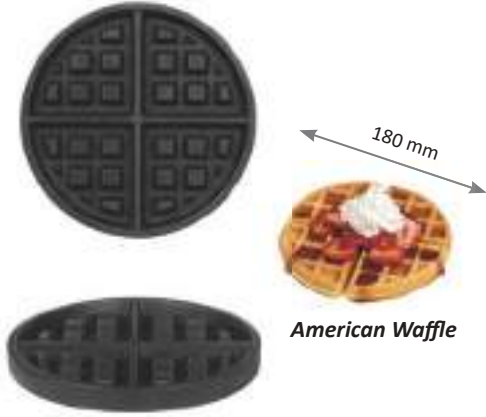

0mk.WFL01.KLP.0101.000

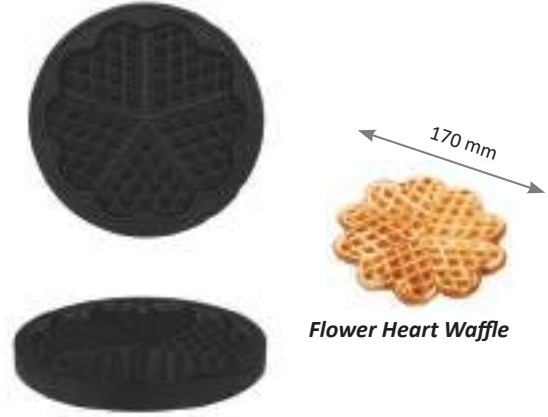

0mk.WFL01.KLP.0201.000

KOD / CODE					
0mk.WFL01.KLP.0101.000	190x190x40 mm	2,0 kg	200x200x50 mm	2.5 Kg	30,69
0mk.WFL01.KLP.0201.000	190x190x40 mm	2,0 kg	200x200x50 mm	2.5 Kg	30,69



**YUVARLAK WAFFLE MAKİNELERİ**  
ROUND WAFFLE MAKERS



**Omk.WFL11.E12.0101.Z5F**



**Omk.WFL11.E12.0201.Z5F**



KOD / CODE						
Omk.WFL11.E12.0101.Z5F	225x295x295 mm	5,0 kg	230 / 50-60 V/HZ - 1,3 kW	245x345x315 mm	5,5 kg	203,57
Omk.WFL11.E12.0201.Z5F	225x295x295 mm	5,0 kg	230 / 50-60 V/HZ - 1,3 kW	245x345x315 mm	5,5 kg	203,57



**Omk.WFL11.E22.0101.Z5F**



**Omk.WFL11.E22.0201.Z5F**



KOD / CODE						
Omk.WFL11.E22.0101.Z5F	450x295x295 mm	9,0 kg	230 / 50-60 V/HZ - 2,6 kW	470x345x315 mm	9,5kg	354,90
Omk.WFL11.E22.0201.Z5F	450x295x295 mm	9,0 kg	230 / 50-60 V/HZ - 2,6 kW	470x345x315 mm	9,5 kg	354,90



**OmkWFL12.E12.0101.Z5F**



**OmkWFL12.E12.0201.Z5F**



KOD / CODE						
OmkWFL12.E12.0101.Z5F	225x380x315 mm	7,0 kg	230 / 50-60 V/HZ - 1,3 kW	250x430x345 mm	7,5 Kg	235,89
OmkWFL12.E12.0201.Z5F	225x380x315 mm	7,0 kg	230 / 50-60 V/HZ - 1,3 kW	250x430x345 mm	7,5 Kg	235,89



**OmkWFL12.E12.0301.Z5F**



**OmkWFL12.E12.0401.Z5F**



KOD / CODE						
OmkWFL12.E12.0301.Z5F	225x380x315 mm	7,0 kg	230 / 50-60 V/HZ - 1,3 kW	250x430x345 mm	7,5 Kg	235,89
OmkWFL12.E12.0401.Z5F	225x380x315 mm	7,0 kg	230 / 50-60 V/HZ - 1,3 kW	250x430x345 mm	7,5 Kg	235,89

## DÖNER YUVARLAK WAFFLE MAKİNELERİ ROTARY ROUND WAFFLE MAKERS



**Omk.WFL12.E22.0101.Z5F**



**Omk.WFL12.E22.0201.Z5F**



KOD / CODE						
Omk.WFL12.E22.0101.Z5F	450x380x315 mm	12,0 Kg	230 / 50-60 V/Hz - 2,6 kW	465x430x345 mm	12,5 Kg	414,52
Omk.WFL12.E22.0201.Z5F	450x380x315 mm	12,0 Kg	230 / 50-60 V/Hz - 2,6 kW	465x430x345 mm	12,5 Kg	414,52



**Omk.WFL12.E22.0301.Z5F**



**Omk.WFL12.E22.0401.Z5F**



KOD / CODE						
Omk.WFL12.E22.0301.Z5F	450x380x315 mm	12,0 Kg	230 / 50-60 V/Hz - 2,6 kW	465x430x345 mm	12,5 Kg	414,52
Omk.WFL12.E22.0401.Z5F	450x380x315 mm	12,0 Kg	230 / 50-60 V/Hz - 2,6 kW	465x430x345 mm	12,5 Kg	414,52



Omk.WFL11.KLP.0101.000



Omk.WFL11.KLP.0201.000

KOD / CODE					
Omk.WFL11.KLP.0101.000	190x190x40 mm	1,5 Kg	200x200x50 mm	2,0 Kg	14,01
Omk.WFL11.KLP.0201.000	190x190x40 mm	1,5 Kg	200x200x50 mm	2,0 Kg	14,01



Omk.WFL12.KLP.0301.000



Omk.WFL12.KLP.0401.000

KOD / CODE					
Omk.WFL12.KLP.0301.000	190x190x40 mm	1,5 Kg	200x200x50 mm	2,0 Kg	14,01
Omk.WFL12.KLP.0401.000	190x190x40 mm	1,5 Kg	200x200x50 mm	2,0 Kg	14,01

## KARE WAFFLE MAKİNELERİ

SQUARE WAFFLE MAKERS



**TR**

Yeni tasarım, yepyeni bir bakış açısı.  
Yerli imalatın gücüyle birleşti.

**EN**

A new design, a new approach to waffle baking.  
Proudly manufactured in Turkey.



Kolay değiştirilebilir pişirme kalıpları  
Easy to change baking plates  
provides efficient operation

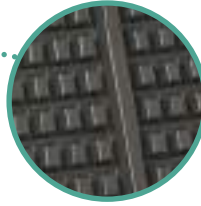

Teflon kaplı yapışmaz pişirme yüzeyi  
Teflon coated non-stick baking plate



Alüminyum teflon kaplama üst gövde  
Aluminium teflon coated top body



**TR**

- Tekli ve çiftli model seçeneği
- Mekanik zamanlayıcı
- Teflon kaplı yapışmaz pişirme yüzeyi ve üst gövde
- Kolay değiştirilebilir teflon pişirme kalıpları
- Farklı şekillerde pişirme kalıpları
- Paslanmaz çelik gömülü ısıtıcılar ile hassas sıcaklık kontrolü
- Farklı sıcaklık ayarında çalıştırma
- Seri pişirmelerde yüksek performans
- Gösterge ve sinyal lambaları
- Paslanmaz çelik alt gövde
- Gıda ile temasa uygun pişirme kalıpları ve gövde

**EN**

- Single and double model options
- Mechanic timer model
- Teflon coated Non-Stick baking plate and top body
- Easy to change teflon coated baking plates
- Different shaped baking plates feature
- Stainless steel embedded heating element for precise temperature control
- Operation with desired heating temperature
- High performance during dynamic operation
- Power ON and Ready-to-Bake LED indicators
- Stainless steel frame body
- Baking plates and body suitable for food contact



**Omk.WFL21.E12.0101.Z5F**

**MANUEL TIMER**  
MANUAL WITH TIMER



**Omk.WFL21.E12.0201.Z5F**

**MANUEL TIMER**  
MANUAL WITH TIMER



**Omk.WFL21.E12.0301.Z5F**

**MANUEL TIMER**  
MANUAL WITH TIMER

KOD / CODE						€
Omk.WFL21.E12.0101.Z5F	270x450x270 mm	13,0 kg	230 / 50-60 V/HZ - 2,5 kW	290x480x300 mm	14,0 Kg	283,46
Omk.WFL21.E12.0201.Z5F	270x450x270 mm	13,0 kg	230 / 50-60 V/HZ - 2,5 kW	290x480x300 mm	14,0 Kg	280,43
Omk.WFL21.E12.0301.Z5F	270x450x270 mm	13,5 kg	230 / 50-60 V/HZ - 2,5 kW	290x480x300 mm	14,5 Kg	286,06



**Omk.WFL21.E12.0501.Z5F**

**MANUEL TIMER**  
MANUAL WITH TIMER



**Omk.WFL21.E12.0601.Z5F**

**MANUEL TIMER**  
MANUAL WITH TIMER



**Omk.WFL21.E12.0701.Z5F**

**MANUEL TIMER**  
MANUAL WITH TIMER

KOD / CODE						€
Omk.WFL21.E12.0501.Z5F	270x450x270 mm	14,0 kg	230 / 50-60 V/HZ - 2,5 kW	290x480x300 mm	15,0 Kg	290,83
Omk.WFL21.E12.0601.Z5F	270x450x270 mm	13,5 kg	230 / 50-60 V/HZ - 2,5 kW	290x480x300 mm	14,5 Kg	286,87
Omk.WFL21.E12.0701.Z5F	270x450x270 mm	14,0 kg	230 / 50-60 V/HZ - 2,5 kW	290x480x300 mm	15,0 Kg	285,46

**KARE WAFFLE MAKİNELERİ**  
SQUARE WAFFLE MAKERS



**Omk.WFL21.E12.1001.Z5F**

MANUEL TIMER  
MANUAL WITH TIMER



**Omk.WFL21.E12.1101.Z5F**

MANUEL TIMER  
MANUAL WITH TIMER



**Omk.WFL21.E12.1201.Z5F**

MANUEL TIMER  
MANUAL WITH TIMER

KOD / CODE						
Omk.WFL21.E12.1001.Z5F	270x450x270 mm	14,0 kg	230 / 50-60 V/HZ - 2,5 kW	290x480x300 mm	15,0 Kg	290,28
Omk.WFL21.E12.1101.Z5F	270x450x270 mm	14,0 kg	230 / 50-60 V/HZ - 2,5 kW	290x480x300 mm	15,0 Kg	291,89
Omk.WFL21.E12.1201.Z5F	270x450x270 mm	13,0 kg	230 / 50-60 V/HZ - 2,5 kW	290x480x300 mm	14,0 Kg	280,76



**Omk.WFL21.E12.1301.Z5F**

MANUEL TIMER  
MANUAL WITH TIMER



**Omk.WFL21.E12.1401.Z5F**

MANUEL TIMER  
MANUAL WITH TIMER



**Omk.WFL21.E12.1501.Z5F**

MANUEL TIMER  
MANUAL WITH TIMER

KOD / CODE						
Omk.WFL21.E12.1301.Z5F	270x450x270 mm	13,5 kg	230 / 50-60 V/HZ - 2,5 kW	290x480x300 mm	14,5 kg	289,87
Omk.WFL21.E12.1401.Z5F	270x450x270 mm	13,5 kg	230 / 50-60 V/HZ - 2,5 kW	290x480x300 mm	14,5 Kg	286,73
Omk.WFL21.E12.1501.Z5F	270x450x270 mm	14,0 kg	230 / 50-60 V/HZ - 2,5 kW	290x480x300 mm	15,0 Kg	288,99



Omk.WFL21.E22.0101.Z50



Omk.WFL21.E22.0201.Z50



Omk.WFL21.E22.0301.Z50



KOD / CODE						
Omk.WFL21.E22.0101.Z50	560x450x270 mm	27,0 kg	230 / 50-60 V/Hz - 5,0 kW	580x480x300 mm	28,5 Kg	531,56
Omk.WFL21.E22.0201.Z50	560x450x270 mm	26,5 kg	230 / 50-60 V/Hz - 5,0 kW	580x480x300 mm	28,0 Kg	524,51
Omk.WFL21.E22.0301.Z50	560x450x270 mm	27,0 kg	230 / 50-60 V/Hz - 5,0 kW	580x480x300 mm	28,5 Kg	536,64



Omk.WFL21.E22.0501.Z50



Omk.WFL21.E22.0601.Z50



Omk.WFL21.E22.0701.Z50



KOD / CODE						
Omk.WFL21.E22.0501.Z50	560x450x270 mm	28,0 kg	230 / 50-60 V/Hz - 5,0 kW	580x480x300 mm	29,5 Kg	546,17
Omk.WFL21.E22.0601.Z50	560x450x270 mm	27,5 kg	230 / 50-60 V/Hz - 5,0 kW	580x480x300 mm	29,0 Kg	538,25
Omk.WFL21.E22.0701.Z50	560x450x270 mm	27,0 kg	230 / 50-60 V/Hz - 5,0 kW	580x480x300 mm	28,5 Kg	535,45

**KARE WAFFLE MAKİNELERİ**  
SQUARE WAFFLE MAKERS



**Omk.WFL21.E22.1001.Z50**



**Omk.WFL21.E22.1101.Z50**



**Omk.WFL21.E22.1201.Z50**



KOD / CODE							€
Omk.WFL21.E22.1001.Z50	560x450x270 mm	28,0 kg	230 / 50-60 V/HZ - 5,0 kW	580x480x300 mm	29,5 kg	545,08	
Omk.WFL21.E22.1101.Z50	560x450x270 mm	28,0 kg	230 / 50-60 V/HZ - 5,0 kW	580x480x300 mm	29,0 Kg	548,30	
Omk.WFL21.E22.1201.Z50	560x450x270 mm	26,0 kg	230 / 50-60 V/HZ - 5,0 kW	580x480x300 mm	27,5 Kg	526,04	



**Omk.WFL21.E22.1301.Z50**



**Omk.WFL21.E22.1401.Z50**



**Omk.WFL21.E22.1501.Z50**



KOD / CODE							€
Omk.WFL21.E22.1301.Z50	560x450x270 mm	28,5 kg	230 / 50-60 V/HZ - 5,0 kW	580x480x300 mm	29,0 kg	544,14	
Omk.WFL21.E22.1401.Z50	560x450x270 mm	27,0 kg	230 / 50-60 V/HZ - 5,0 kW	580x480x300 mm	28,5 Kg	537,86	
Omk.WFL21.E22.1501.Z50	560x450x270 mm	28,0 kg	230 / 50-60 V/HZ - 5,0 kW	580x480x300 mm	29,5 Kg	542,59	



0101 KALIP / PLATE  
Brüksel 3x5

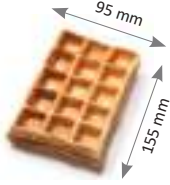

0201 KALIP / PLATE  
Brüksel 4x6

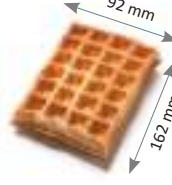

0301 KALIP / PLATE  
Brüksel 3x5 Mini

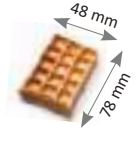

KOD / CODE					€
Omk.WFL21.KLP.0101.000	250x250x50 mm	5,0 kg	270x280x60 mm	5,5 kg	87,55
Omk.WFL21.KLP.0201.000	250x250x50 mm	5,0 kg	270x280x60 mm	5,5 kg	87,55
Omk.WFL21.KLP.0301.000	250x250x50 mm	5,5 kg	270x280x60 mm	6,0 kg	87,55



0501 KALIP / PLATE  
Coin

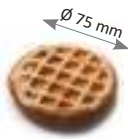

0601 KALIP / PLATE  
Balls Ø33



0701 KALIP / PLATE  
Stick Heart

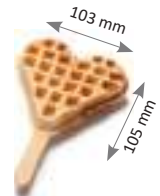

KOD / CODE					€
Omk.WFL21.KLP.0501.000	250x250x50 mm	6,0 kg	270x280x60 mm	6,5 kg	87,55
Omk.WFL21.KLP.0601.000	250x250x50 mm	5,5 kg	270x280x60 mm	6,0 kg	87,55
Omk.WFL21.KLP.0701.000	250x250x50 mm	5,5 kg	270x280x60 mm	6,0 kg	87,55

**KARE WAFFLE MAKİNE KALIPLARI**  
SQUARE WAFFLE MAKER BAKING PLATES



1001 KALIP / PLATE  
Balls  $\varnothing$ 30



1101 KALIP / PLATE  
Stick Pine



1201 KALIP / PLATE  
Americano

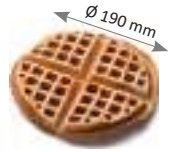

KOD / CODE					
Omk.WFL21.KLP.1001.000	250x250x50 mm	6,0 kg	270x280x60 mm	6,5 kg	87,55
Omk.WFL21.KLP.1101.000	250x250x50 mm	6,0 kg	270x280x60 mm	6,5 kg	87,55
Omk.WFL21.KLP.1201.000	250x250x50 mm	5,0 kg	270x280x60 mm	5,5 kg	87,55



1301 KALIP / PLATE  
Heart  $\varnothing$ 190

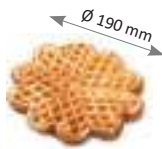

1401 KALIP / PLATE  
Heart  $\varnothing$ 220



1501 KALIP / PLATE  
Balls  $\varnothing$ 64



KOD / CODE					
Omk.WFL21.KLP.1301.000	250x250x50 mm	5,5 kg	270x280x60 mm	6,0 kg	87,55
Omk.WFL21.KLP.1401.000	250x250x50 mm	5,5 kg	270x280x60 mm	6,0 kg	87,55
Omk.WFL21.KLP.1501.000	250x250x50 mm	6,0 kg	270x280x60 mm	6,5 kg	87,55

## DONUT MAKİNELERİ

DONUT MAKERS

**omake**  
All Kitchen Equipments



Omk.DNT01.E12.0401.Z5F

MANUEL TIMER  
MANUAL WITH TIMER



Omk.DNT01.E22.0401.Z50

MANUEL TIMER  
MANUAL WITH TIMER



0401 KALIP / PLATE  
Donut

KOD / CODE						€
Omk.DNT01.E12.0401.Z5F	270x450x270 mm	13,5 kg	230 / 50-60 V/Hz - 2,5 kW	290x480x300 mm	14,5 kg	285,57
Omk.DNT01.E22.0401.Z50	560x450x270 mm	27,0 kg	230 / 50-60 V/Hz - 5,0 kW	580x480x300 mm	28,5 Kg	535,66
Omk.DNT01.KLP.0401.000	250x250x50 mm	5,5 kg	-	270x280x60 mm	6,0 kg	89,58

## CHURROS MAKİNELERİ

CHURROS MAKERS



Omk.CHR01.E12.0801.Z5F

MANUEL TIMER  
MANUAL WITH TIMER



Omk.CHR01.E22.0801.Z50

MANUEL TIMER  
MANUAL WITH TIMER



0801 KALIP / PLATE  
Churros

KOD / CODE						€
Omk.CHR01.E12.0801.Z5F	270x450x270 mm	13,5 kg	230 / 50-60 V/Hz - 2,5 kW	290x480x300 mm	14,5 kg	286,82
Omk.CHR01.E22.0801.Z50	560x450x270 mm	27,5 kg	230 / 50-60 V/Hz - 5,0 kW	580x480x300 mm	29,0 kg	538,16
Omk.CHR01.KLP.0801.000	250x250x50 mm	6,0 kg	-	270x280x60 mm	6,5 kg	90,82

**KORNET MAKİNELERİ**  
CORNET MAKERS



Omk.KRN01.E12.0901.Z5F



MANUEL TİMER  
MANUAL WITH TIMER



Omk.KRN01.E22.0901.Z50



MANUEL TİMER  
MANUAL WITH TIMER

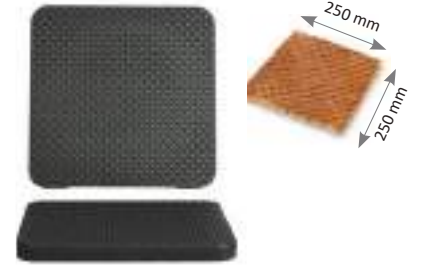

0901 KALIP / PLATE  
Corn Waffle

KOD / CODE							
Omk.KRN01.E12.0901.Z5F	270x450x270 mm	15,0 kg	230 / 50-60 V/HZ - 2,5 kW	290x480x300 mm	16,0 kg	302,66	
Omk.KRN01.E22.0901.Z50	560x450x270 mm	29,5 kg	230 / 50-60 V/HZ - 5,0 kW	580x480x300 mm	31,0 kg	569,84	
Omk.KRN01.KLP.0901.000	250x250x50 mm	7,0 kg	-	270x280x60 mm	7,5 kg	106,66	

KOD / CODE	KALIP ADI	PIŞİRME SÜRESİ (Dk)	HAMUR (Gr)	PIŞİRME DERECEŚİ
Omk.WFL21.KLP.0101.000	Brüksel 3x5	3,5 - 4,5	200	210 - 230 °C
Omk.WFL21.KLP.0201.000	Brüksel 4x6	3,5 - 4,5	250	210 - 230 °C
Omk.WFL21.KLP.0301.000	Brüksel 3x5 Mini	3,0 - 4,0	125	210 - 230 °C
Omk.DNT01.KLP.0401.000	Donut	3,0 - 4,0	200	210 - 230 °C
Omk.WFL21.KLP.0501.000	Coin	3,0 - 4,0	150	210 - 230 °C
Omk.WFL21.KLP.0601.000	Balls Ø33	3,0 - 4,0	250	210 - 230 °C
Omk.WFL21.KLP.0701.000	Çubuklu Kalp	3,5 - 4,5	150	210 - 230 °C
Omk.CHR01.KLP.0801.000	Churros Kalıp	3,5 - 4,5	200	210 - 230 °C
Omk.KRN01.KLP.0901.000	Kornet	1,0-1,5	50	210 - 230 °C
Omk.WFL21.KLP.1001.000	Balls Ø30	3,0 - 4,0	150	210 - 230 °C
Omk.WFL21.KLP.1101.000	Çubuklu Çam	3,0 - 4,0	250	210 - 230 °C
Omk.WFL21.KLP.1201.000	Amerikan	4,0 - 5,5	250	210 - 230 °C
Omk.WFL21.KLP.1301.000	Kalp Ø190	3,0 - 4,0	200	210 - 230 °C
Omk.WFL21.KLP.1401.000	Kalp Ø220	3,0 - 4,0	250	210 - 230 °C
Omk.WFL21.KLP.1501.000	Balls Ø64	3,0 - 4,0	200	210 - 230 °C

Tavsiye edilen gramaj-süre ve derecelerdir. Reçetenize ve isteğimize göre sonuç alabilmek için kendi değerlerinizi oluşturabilirsiniz.

Pişirme süreleri ve dereceleri reçeteye (kullanılan şeker,su,süt, kabartma tozu, yumurta miktarları etkindir) göre değişiklik gösterebilir. Kendi reçetenize en uygun süre ve dereceyi deneme yaparak tespit edebilirsiniz.

Hamur gramajları +/- 50 gr değişiklik gösterebilir. Reçeteniz veya talep edilen incelik/kalınlık durumuna göre kendi tarifinizi denemelerle tespit edebilirsiniz.

**TR**

Yeni tasarım, yepyeni bir bakış açısı.  
Yerli imalatın gücüyle birleşti.

**EN**

A new design, a new approach to waffle baking.  
Proudly manufactured in Turkey.



Kolay değiştirilebilir pişirme kalıpları  
Easy to change baking plates  
provides efficient operation



Teflon kaplı yapışmaz pişirme yüzeyi  
Teflon coated non-stick baking plate



Alüminyum teflon kaplamalı gövde  
Aluminium teflon coated body



**TR**

- Tekli ve çiftli model seçeneği
- Manuel model
- Teflon kaplı yapışmaz pişirme yüzeyi ve üst gövde
- Kolay değiştirilebilir teflon pişirme kalıpları
- Farklı şekillerde pişirme kalıpları
- Paslanmaz çelik gömülü ısıtıcılar ile hassas sıcaklık kontrolü
- Farklı sıcaklık ayarlarında çalıştırma
- Seri pişirmelerde yüksek performans
- Gösterge ve sinyal lambaları
- Paslanmaz çelik alt gövde
- Gıda ile temasa uygun pişirme kalıpları ve gövde

**EN**

- Single and double model options
- Manual model
- Teflon coated Non-Stick baking plate and top body
- Easy to change teflon coated baking plates
- Different shaped baking plates feature
- Stainless steel embedded heating element for precise temperature control
- Operation with desired heating temperature
- High performance during dynamic operation
- Power ON and Ready-to-Bake LED indicators
- Stainless steel frame body
- Baking plates and body suitable for food contact

**POFFERTJES WAFFLE MAKİNELERİ**  
POFFERTJES WAFFLE MAKERS



**Omk.PFR01.E11.0601.Z5F**



**Omk.PFR01.E11.1001.Z5F**



**Omk.PFR01.E11.1501.Z5F**



KOD / CODE						€
Omk.PFR01.E11.0601.Z5F	270x380x200 mm	8,0 kg	230 / 50-60 V/HZ - 1,5 kW	310x410x230 mm	9,5 kg	168,34
Omk.PFR01.E11.1001.Z5F	270x380x200 mm	8,5 kg	230 / 50-60 V/HZ - 1,5 kW	310x410x230 mm	10,0 Kg	170,04
Omk.PFR01.E11.1501.Z5F	270x380x200 mm	8,5 kg	230 / 50-60 V/HZ - 1,5 kW	310x410x230 mm	10,0 kg	169,50



**Omk.PFR01.E21.0601.Z5F**



**Omk.PFR01.E21.1001.Z5F**



**Omk.PFR01.E21.1501.Z5F**



KOD / CODE						€
Omk.PFR01.E21.0601.Z5F	560x380x200 mm	15,0 kg	230 / 50-60 V/HZ - 3,0 kW	580x410x230 mm	17,5 kg	293,06
Omk.PFR01.E21.1001.Z5F	560x380x200 mm	16,0 kg	230 / 50-60 V/HZ - 3,0 kW	580x410x230 mm	18,0 kg	304,82
Omk.PFR01.E21.1501.Z5F	560x380x200 mm	16,0 kg	230 / 50-60 V/HZ - 3,0 kW	580x410x230 mm	18,0 kg	303,75

**POFFERTJES WAFFLE MAKİNE KALIPLARI**  
POFFERTJES WAFFLE MAKER BAKING PLATES

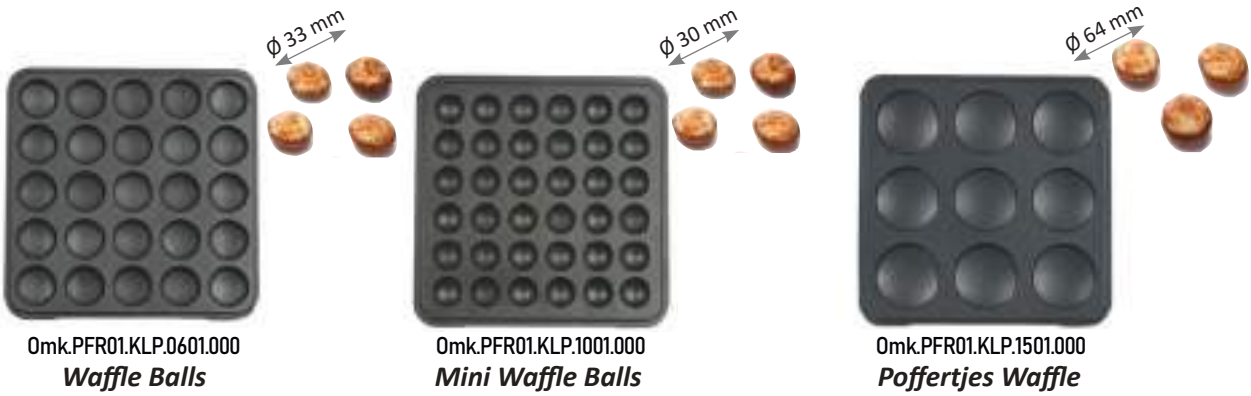

KOD / CODE					
Omk.PFR01.KLP.0601.000	250x250x25 mm	3,0 kg	270x280x40 mm	3,5 kg	46,42
Omk.PFR01.KLP.1001.000	250x250x25 mm	3,0 kg	270x280x40 mm	3,5 kg	46,42
Omk.PFR01.KLP.1501.000	250x250x25 mm	3,0 kg	270x280x40 mm	3,5 kg	47,59





Teflon yapışmaz veya  
döküm pişirme yüzeyi

Teflon coated non-stick baking  
plate or cast iron options



Gazlı modellerde kolay  
değiştirilebilir pişirme kalıpları

Easy to change baking plates provides  
efficient operation for  
Gas operated models

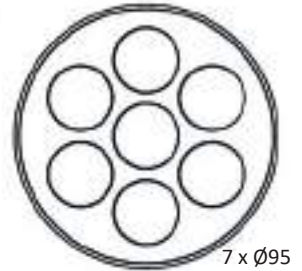
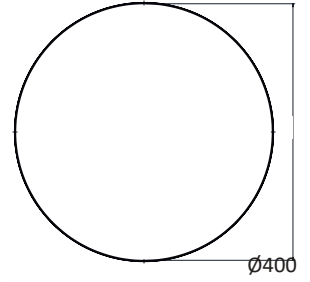

**TR**

- Elektrikli veya gazlı modeller
- Tekli ve çiftli model seçeneği
- Manuel model
- Teflon veya döküm pişirme yüzeyi
- Gazlı modellerde kolay değiştirilebilir pişirme kalıpları
- Farklı şekillerde pişirme kalıpları
- Paslanmaz çelik gömülü ısıtıcılar ile hassas sıcaklık kontrolü
- Farklı sıcaklık ayarında çalıştırma
- Seri pişirmelerde yüksek performans
- Gösterge ve sinyal lambası
- Paslanmaz çelik gövde
- Gıda ile temasa uygun pişirme kalıpları ve gövde

**EN**

- Electric or gas operated options
- Single and double model options
- Manual model
- Teflon coated non stick baking plate or cast iron options
- For gas operated models, easy to change baking plates
- Different shaped baking plates feature
- Stainless steel embedded heating element for precise temperature control
- Operation with desired heating temperature
- High performance during dynamic operation
- Power ON and Ready-to-Bake LED indicator
- Stainless steel body
- Baking plates and body suitable for food contact



Omk.KRP03.E11.0000.Z5F



Omk.KRP03.E11.0007.Z5F



KOD / CODE						
Omk.KRP03.E11.0000.Z5F	405x440x180 mm	14,0 kg	230 / 50-60 V/HZ - 2,5 kW	440x480x230 mm	14,5 kg	203,61
Omk.KRP03.E11.0007.Z5F	405x440x180 mm	12,5 kg	230 / 50-60 V/HZ - 2,5 kW	440x480x230 mm	13,0 kg	203,61



Omk.KRP03.E21.0000.Z5F



Omk.KRP03.E21.0007.Z5F



KOD / CODE						
Omk.KRP03.E21.0000.Z5F	835x440x180 mm	25,0 kg	230 / 50-60 V/HZ - 2x2,5 kW	870x500x230 mm	26,0 kg	381,39
Omk.KRP03.E21.0007.Z5F	835x440x180 mm	26,0 kg	230 / 50-60 V/HZ - 2x2,5 kW	870x500x230 mm	27,0 kg	381,39

**ELEKTRİKLİ TEFLONLU KREP MAKİNELERİ**  
ELECTRIC CREPE MAKERS WITH TEFLON



**Omk.KRP04.E11.0000.Z5F**



**Omk.KRP04.E11.0007.Z5F**



KOD / CODE						
Omk.KRP04.E11.0000.Z5F	405x440x180 mm	14,0 kg	230 / 50-60 V/HZ - 2,5 kW	440x480x230 mm	14,5 kg	209,22
Omk.KRP04.E11.0007.Z5F	405x440x180 mm	12,5 kg	230 / 50-60 V/HZ - 2,5 kW	440x480x230 mm	13,0 kg	209,22



**Omk.KRP04.E21.0000.Z5F**



**Omk.KRP04.E21.0007.Z5F**



KOD / CODE						
Omk.KRP04.E21.0000.Z5F	835x440x180 mm	25,0 kg	230 / 50-60 V/HZ - 2x2,5 kW	870x500x230 mm	26,0 kg	393,24
Omk.KRP04.E21.0007.Z5F	835x440x180 mm	26,0 kg	230 / 50-60 V/HZ - 2x2,5 kW	870x500x230 mm	27,0 kg	393,24

## ELEKTRİKLİ TEFLONSUZ KREP MAKİNELERİ

ELECTRIC CREPE MAKERS WITHOUT TEFLON

**omake**  
All Kitchen Equipments

1  
CAFE&BAR  
CAFE&BAR



Omk.KRP11.E11.0000.Z5F



Omk.KRP11.E11.0007.Z5F



KOD / CODE							
Omk.KRP11.E11.0000.Z5F	400x420x140 mm	12,5 kg	230 / 50-60 V/HZ - 2,5 kW	435x435x180 mm	13,0 kg	185,19	
Omk.KRP11.E11.0007.Z5F	400x420x140 mm	11,5 kg	230 / 50-60 V/HZ - 2,5 kW	435x435x180 mm	12,0 kg	185,19	

## ELEKTRİKLİ TEFLONLU KREP MAKİNELERİ

ELECTRIC CREPE MAKERS WITH TEFLON



Omk.KRP12.E11.0000.Z5F



Omk.KRP12.E11.0007.Z5F



KOD / CODE							
Omk.KRP12.E11.0000.Z5F	400x420x140 mm	12,5 kg	230 / 50-60 V/HZ - 2,5 kW	435x435x180 mm	13,0 kg	190,73	
Omk.KRP12.E11.0007.Z5F	400x420x140 mm	11,5 kg	230 / 50-60 V/HZ - 2,5 kW	435x435x180 mm	12,0 kg	190,73	

**GAZLI KREP MAKİNELERİ**  
GAS CREPE MAKERS



**Omk.KRP03.N11.0000.000**



**Omk.KRP03.N11.0007.000**



KOD / CODE						€
Omk.KRP03.N11.0000.000	405x460x195 mm	18,0 kg	NG / 21 mbar / 6,04 kW	440x480x230 mm	18,5 kg	263,11
Omk.KRP03.N11.0007.000	405x460x195 mm	16,0 kg	NG / 21 mbar / 6,04kW	440x480x230 mm	16,5 kg	263,11



**Omk.KRP11.N11.0000.000**



**Omk.KRP11.N11.0007.000**



KOD / CODE						€
Omk.KRP11.N11.0000.000	405x460x195 mm	18,0 kg	NG / 21 mbar / 6,04 kW	440x480x230 mm	18,5 kg	275,65
Omk.KRP11.N11.0007.000	405x460x195 mm	16,0 kg	NG / 21 mbar / 6,04kW	440x480x230 mm	16,5 kg	272,08



DÜZ TEFLON KALIP  
TEFLON FLAT PLATE



7'Li TEFLON KALIP  
TEFLON 7 SHAPE PLATE

KOD / CODE					
Omk.KRP99.KLP.0000.001	400x400x30 mm	9,5 kg	420x420x40 mm	10,0 kg	88,07
Omk.KRP99.KLP.0007.001	400x400x30 mm	7,5 kg	420x420x40 mm	8,0 kg	88,07



DÜZ KALIP  
FLAT PLATE

7'Li KALIP  
7 SHAPE PLATE

KOD / CODE					
Omk.KRP99.KLP.0000.000	400x400x30 mm	9,5 kg	420x420x40 mm	10,0 kg	82,54
Omk.KRP99.KLP.0007.000	400x400x30 mm	7,5 kg	420x420x40 mm	8,0 kg	82,54



## PANKEK MAKİNELERİ

PANCAKE MAKERS

**omake**  
All Kitchen Equipments



Gazlı ve elektrikli model seçenekleri  
Available both, electrical and gas operated



14 x Ø78



37 x Ø40



### TR

- Elektrikli veya gazlı modeller
- Tekli ve çiftli model seçeneği
- Manuel model
- Teflon veya döküm pişirme yüzeyi
- Gazlı modellerde kolay değiştirilebilir pişirme kalıpları
- Farklı şekillerde pişirme kalıpları
- Paslanmaz çelik gömülü ısıtıcılar ile hassas sıcaklık kontrolü
- Farklı sıcaklık ayarında çalıştırma
- Seri pişirmelerde yüksek performans
- Gösterge ve sinyal lambaları
- Paslanmaz çelik gövde
- Gıda ile temasa uygun pişirme kalıpları ve gövde

### EN

- Electric or gas operated options
- Single and double model options
- Manual model
- Teflon coated non stick baking plate or cast iron options
- For gas operated models, easy to change baking plates
- Different shaped baking plates feature
- Stainless steel embedded heating element for precise temperature control
- Operation with desired heating temperature
- High performance during dynamic operation
- Power ON and Ready-to-Bake LED indicators
- Stainless steel body
- Baking plates and body suitable for food contact

**ELEKTRİKLİ TEFLONSUZ PANKEK MAKİNELERİ**  
ELECTRIC PANCAKE MAKERS WITHOUT TEFLON

**omake**  
All Kitchen Equipments

1  
CAFE&BAR  
CAFE&BAR



**Omk.PNK03.E11.0014.Z5F**



**Omk.PNK03.E11.0037.Z5F**



KOD / CODE						€
Omk.PNK03.E11.0014.Z5F	405x440x180 mm	14,5 kg	230 / 50-60 V/Hz - 2,5 kW	440x480x230 mm	14,5 kg	199,58
Omk.PNK03.E11.0037.Z5F	405x440x180 mm	13,5 kg	230 / 50-60 V/Hz - 2,5 kW	440x480x230 mm	13,0 kg	199,58



**Omk.PNK03.E21.0014.Z5F**



**Omk.PNK03.E21.0037.Z5F**



KOD / CODE						€
Omk.PNK03.E21.0014.Z5F	835x440x180 mm	27,5 kg	230 / 50-60 V/Hz - 2x2,5 kW	870x500x230 mm	28,5 kg	373,34
Omk.PNK03.E21.0037.Z5F	835x440x180 mm	26,0 kg	230 / 50-60 V/Hz - 2x2,5 kW	870x500x230 mm	27,0 kg	373,34

**ELEKTRİKLİ TEFLONLU PANKEK MAKİNELERİ**  
ELECTRIC PANCAKE MAKERS WITH TEFLON



**Omk.PNK04.E11.0014.Z5F**



**Omk.PNK04.E11.0037.Z5F**



KOD / CODE						€
Omk.PNK04.E11.0014.Z5F	405x440x180 mm	14,5 kg	230 / 50-60 V/Hz - 2,5 kW	440x480x230 mm	15,0 kg	207,16
Omk.PNK04.E11.0037.Z5F	405x440x180 mm	13,5 kg	230 / 50-60 V/Hz - 2,5 kW	440x480x230 mm	14,0 kg	207,16



**Omk.PNK04.E21.0014.Z5F**



**Omk.PNK04.E21.0037.Z5F**



KOD / CODE						€
Omk.PNK04.E21.0014.Z5F	835x440x180 mm	27,5 kg	230 / 50-60 V/Hz - 2x2,5 kW	870x500x230 mm	28,5 kg	389,43
Omk.PNK04.E21.0037.Z5F	835x440x180 mm	26,0 kg	230 / 50-60 V/Hz - 2x2,5 kW	870x500x230 mm	27,0 kg	389,43

## ELEKTRİKLİ TEFLONSUZ PANKEK MAKİNELERİ

ELECTRIC PANCAKE MAKERS WITHOUT TEFLON

**omake**  
All Kitchen Equipments

1  
CAFE&BAR  
CAFE&BAR



Omk.PNK11.E11.0014.Z5F



Omk.PNK11.E11.0037.Z5F



KOD / CODE						€
Omk.PNK11.E11.0014.Z5F	400x420x140 mm	12,5 kg	230 / 50-60 V/Hz - 2,5 kW	435x435x180 mm	13,0 kg	181,17
Omk.PNK11.E11.0037.Z5F	400x420x140 mm	12,0 kg	230 / 50-60 V/Hz - 2,5 kW	435x435x180 mm	12,5 kg	181,17

## ELEKTRİKLİ TEFLONLU PANKEK MAKİNELERİ

ELECTRIC PANCAKE MAKERS WITH TEFLON



Omk.PNK12.E11.0014.Z5F



Omk.PNK12.E11.0037.Z5F



KOD / CODE						€
Omk.PNK12.E11.0014.Z5F	400x420x140 mm	12,5 kg	230 / 50-60 V/Hz - 2,5 kW	435x435x180 mm	13,0 kg	188,75
Omk.PNK12.E11.0037.Z5F	400x420x140 mm	12,0 kg	230 / 50-60 V/Hz - 2,5 kW	435x435x180 mm	12,5 kg	188,75

**GAZLI PANKEK MAKİNELERİ**  
GAS PANCAKE MAKERS



**Omk.PNK03.N11.0014.000**



**Omk.PNK03.N11.0037.000**



KOD / CODE						€
Omk.PNK03.N11.0014.000	405x460x195 mm	17,5 kg	NG / 21 mbar / 6,04 kW	440x480x230 mm	18,0 kg	259,01
Omk.PNK03.N11.0037.000	405x460x195 mm	16,5 kg	NG / 21 mbar / 6,04 kW	440x480x230 mm	17,0 kg	259,01



**Omk.PNK11.N11.0014.000**



**Omk.PNK11.N11.0037.000**



KOD / CODE						€
Omk.PNK11.N11.0014.000	405x460x195 mm	17,5 kg	NG / 21 mbar / 6,04 kW	440x480x230 mm	18,0 kg	271,63
Omk.PNK11.N11.0037.000	405x460x195 mm	16,5 kg	NG / 21 mbar / 6,0 kW	440x480x230 mm	17,0 kg	267,60



14'li TEFLON KALIP  
TEFLON 14 SHAPE PLATE

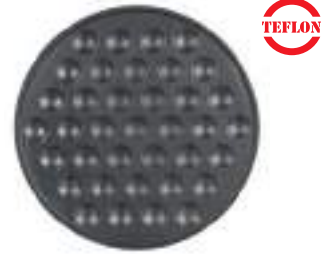

37'li TEFLON KALIP  
TEFLON 37 SHAPE PLATE

KOD / CODE					
Omk.PNK99.KLP.0014.001	400x400x30 mm	9,0 kg	420x420x40 mm	9,5 kg	86,09
Omk.PNK99.KLP.0037.001	400x400x30 mm	8,0 kg	420x420x40 mm	8,5 kg	86,09



14'li KALIP  
14 SHAPE PLATE



37'li KALIP  
37 SHAPE PLATE

KOD / CODE					
Omk.PNK99.KLP.0014.000	400x400x30 mm	9,0 kg	420x420x40 mm	9,5 kg	78,51
Omk.PNK99.KLP.0037.000	400x400x30 mm	8,0 kg	420x420x40 mm	8,5 kg	78,51



**TR**

- Tekli ve ikili, manuel ve dijital model seçenekleri
- Yeni sistem kırılmaz musluk.
- Elektromanyetik pompa / sessiz redüktör motoru.
- Paslanmaz çelik yan ve ön saclar.
- Sessiz, dayanıklı, güçlü kompresör.
- Dizaynı sayesinde kolay bakım ve temizlik sağlar.
- Üstün soğutma performansı.
- Karıştırıcılı ve fıskiyeli model seçenekleri.

**EN**

- Single and double, manual and digital model options
- Hygienic, break-resistant, polycarbonate bowl.
- The new system taps.
- Electromagnetic pump / silent stirring motor.
- Stainless steel case.
- Quiet, durable, powerful compressor.
- Superior cooling power.
- Mixer and sprinkler model options.



**YUVARLAK ŞERBETLİK MAKİNELERİ**  
ROUND JUICE DISPENSER



**Omk.SBY01.E11.0101.Z5F**

-  **MANUEL**  
MANUAL
-  **22 LT KAPASİTE**  
22 LT CAPACITY
-  **KARIŞTIRICILI**  
MIXER



**Omk.SBY01.E11.0201.Z5F**

-  **MANUEL**  
MANUAL
-  **22 LT KAPASİTE**  
22 LT CAPACITY
-  **FİSKİYELİ**  
WITH SPRAY

KOD / CODE					
Omk.SBY01.E11.0101.Z5F	205x535x745 mm	18,5 kg	250x580x820 mm	23,0 kg	776,63
Omk.SBY01.E11.0201.Z5F	205x535x745 mm	19,5 kg	250x580x820 mm	24,0 kg	743,21







**Omk.SBY01.E21.0101.Z5F**

-  **MANUEL**  
MANUAL
-  **22+22 LT KAPASİTE**  
22+22 LT CAPACITY
-  **KARIŞTIRICILI**  
MIXER



**Omk.SBY01.E21.0201.Z5F**

-  **MANUEL**  
MANUAL
-  **22+22 LT KAPASİTE**  
22+22 LT CAPACITY
-  **FİSKİYELİ**  
WITH SPRAY

KOD / CODE					
Omk.SBY01.E21.0101.Z5F	405x535x745 mm	28,5 kg	460x580x820 mm	35,0 kg	1.250,56
Omk.SBY01.E21.0201.Z5F	405x535x745 mm	30,5 kg	460x580x820 mm	36,0 kg	1.182,05



**Omk.SBY01.E15.0101.Z5F**

-  **DİJİTAL**  
DIGITAL
-  **22 LT KAPASİTE**  
22 LT CAPACITY
-  **KARIŞTIRICILI**  
MIXER



**Omk.SBY01.E15.0201.Z5F**

-  **DİJİTAL**  
DIGITAL
-  **22 LT KAPASİTE**  
22 LT CAPACITY
-  **FİSKİYELİ**  
WITH SPRAY

KOD / CODE					
Omk.SBY01.E15.0101.Z5F	205x535x745 mm	18,5 kg	250x580x820 mm	23,0 kg	806,70
Omk.SBY01.E15.0201.Z5F	205x535x745 mm	19,5 kg	250x580x820 mm	24,0 kg	772,66







**Omk.SBY01.E25.0101.Z5F**

-  **DİJİTAL**  
DIGITAL
-  **22+22 LT KAPASİTE**  
22+22 LT CAPACITY
-  **KARIŞTIRICILI**  
MIXER



**Omk.SBY01.E25.0201.Z5F**

-  **DİJİTAL**  
DIGITAL
-  **22+22 LT KAPASİTE**  
22+22 LT CAPACITY
-  **FİSKİYELİ**  
WITH SPRAY

KOD / CODE					
Omk.SBY01.E25.0101.Z5F	405x535x745 mm	28,5 kg	460x580x820 mm	35,0 kg	1.308,43
Omk.SBY01.E25.0201.Z5F	405x535x745 mm	30,5 kg	460x580x820 mm	36,5 kg	1.240,45

**DİKDÖRTGEN ŞERBETLİK MAKİNELERİ**  
RECTANGLE JUICE DISPENSER



**Omk.SBD01.E11.0101.Z5F**

- MANUEL**  
MANUAL
- 20 LT KAPASİTE**  
20 LT CAPACITY
- KARIŞTIRICILI**  
MIXER



**Omk.SBD01.E11.0201.Z5F**

- MANUEL**  
MANUAL
- 20 LT KAPASİTE**  
20 LT CAPACITY
- FİSKİYELİ**  
WITH SPRAY

KOD / CODE					
Omk.SBD01.E11.0101.Z5F	335x390x750 mm	19,0 kg	380x440x820 mm	23,5 kg	804,54
Omk.SBD01.E11.0201.Z5F	335x390x750 mm	20,0 kg	380x440x820 mm	24,5 kg	770,22



**Omk.SBD01.E21.0101.Z5F**

- MANUEL**  
MANUAL
- 20+20 LT KAPASİTE**  
20+20 LT CAPACITY
- KARIŞTIRICILI**  
MIXER



**Omk.SBD01.E21.0201.Z5F**

- MANUEL**  
MANUAL
- 20+20 LT KAPASİTE**  
20+20 LT CAPACITY
- FİSKİYELİ**  
WITH SPRAY

KOD / CODE					
Omk.SBD01.E21.0101.Z5F	715x390x750 mm	28,5 kg	750x440x820 mm	35,0 kg	1.388,37
Omk.SBD01.E21.0201.Z5F	715x390x750 mm	30,5 kg	750x440x820 mm	36,5 kg	1.319,74



**Omk.SBD01.E15.0101.Z5F**

-  **DİJİTAL**  
DIGITAL
-  **20 LT KAPASİTE**  
20 LT CAPACITY
-  **KARIŞTIRICILI**  
MIXER



**Omk.SBD01.E15.0201.Z5F**

-  **DİJİTAL**  
DIGITAL
-  **20 LT KAPASİTE**  
20 LT CAPACITY
-  **FİSKİYELİ**  
WITH SPRAY

KOD / CODE					€
Omk.SBD01.E15.0101.Z5F	335x390x750 mm	19,0 kg	380x440x820 mm	23,5 kg	833,63
Omk.SBD01.E15.0201.Z5F	335x390x750 mm	20,0 kg	380x440x820 mm	24,5 kg	799,57







**Omk.SBD01.E25.0101.Z5F**

-  **DİJİTAL**  
DIGITAL
-  **20+20 LT KAPASİTE**  
20+20 LT CAPACITY
-  **KARIŞTIRICILI**  
MIXER



**Omk.SBD01.E25.0201.Z5F**

-  **DİJİTAL**  
DIGITAL
-  **20+20 LT KAPASİTE**  
20+20 LT CAPACITY
-  **FİSKİYELİ**  
WITH SPRAY

KOD / CODE					€
Omk.SBD01.E25.0101.Z5F	715x390x750 mm	28,5 kg	750x440x820 mm	35,0 kg	1.388,66
Omk.SBD01.E25.0201.Z5F	715x390x750 mm	30,5 kg	750x440x820 mm	36,5 kg	1.378,42

**TOST MAKİNELERİ**  
TOASTERS**TR**

- Tost makineleri sık kullanım için en iyi performansı verir.
- Paslanmaz çelik kasalıdır.
- Isı yalıtımlı plastik saplar.
- Otomatik termostatlıdır.



**EN**

- The best performance for frequent use.
- Stainless steel body.
- Heat resistant plastic handles.
- Automatic thermostat control.







**Omk.TST01.E11.0008.Z5F**

-  Elektrik  
Electric
-  Manuel  
Manual
-  8 Dilim  
8 Slices

KOD / CODE						
Omk.TST01.E11.0008.Z5F	250x405x240 mm	11,5 kg	230 / 50-60 V/HZ - 1,8 kW	270x435x265 mm	12,0 kg	211,32





**Omk.TST01.E11.0012.Z5F**

-  Elektrik  
Electric
-  Manuel  
Manual
-  12 Dilim  
12 Slices

KOD / CODE						
Omk.TST01.E11.0012.Z5F	425x405x240 mm	17,0 kg	230 / 50-60 V/HZ - 2,6 kW	435x435x265 mm	18,0 kg	291,08



**Omk.TST01.E11.0020.Z5F**



-  Elektrik  
Electric
-  Manuel  
Manual
-  20 Dilim  
20 Slices

KOD / CODE						
Omk.TST01.E11.0020.Z5F	515x405x240mm	23,0 kg	230 / 50-60 V/HZ - 3,6 kW	590x435x265 mm	24,0 kg	369,90

**TOST MAKİNELERİ**  
TOASTERS





**Omk.TST01.E11.0116.Z5F**

-  Elektrik  
Electric
-  Manuel  
Manual
-  16 Dilim  
16 Slices

KOD / CODE						
Omk.TST01.E11.0116.Z5F	515x405x240 mm	23,5 kg	230 / 50-60 V/HZ - 3,6 kW	590x435x265 mm	24,5 kg	396,73





**Omk.TST11.E11.0008.Z5F**

-  Elektrik  
Electric
-  Manuel  
Manual
-  8 Dilim  
8 Slices

KOD / CODE						
Omk.TST11.E11.0008.Z5F	265x405x240 mm	14,0 kg	230 / 50-60 V/HZ - 1,8 kW	270x435x265 mm	14,5 kg	229,74





**Omk.TST11.E11.0012.Z5F**





-  Elektrik  
Electric
-  Manuel  
Manual
-  12 Dilim  
12 Slices

KOD / CODE						
Omk.TST11.E11.0012.Z5F	395x405x240 mm	19,0 kg	230 / 50-60 V/HZ - 2,6 kW	435x435x265 mm	20,0 kg	304,81





**Omk.TST11.E11.0020.Z5F**

-  Elektrik  
Electric
-  Manuel  
Manual
-  20 Dilim  
20 Slices

KOD / CODE						
Omk.TST11.E11.0020.Z5F	550x405x240 mm	26,0 kg	230 / 50-60 V/HZ - 3,6 kW	590x435x265 mm	27,0 kg	391,23



**Omk.TST11.E11.0116.Z5F**

-  Elektrik  
Electric
-  Manuel  
Manual
-  16 Dilim  
16 Slices

KOD / CODE						
Omk.TST11.E11.0116.Z5F	550x405x240 mm	26,5 kg	230 / 50-60 V/HZ - 3,6 kW	590x435x265 mm	27,5 kg	432,27



**Omk.TST21.E11.0004.Z5F**

-  Elektrik  
Electric
-  Manuel  
Manual

KOD / CODE						
Omk.TST21.E11.0004.Z5F	350x450x290 mm	22,0 kg	230 / 50-60 V/HZ - 1,8 kW	390x485x315 mm	23,0 kg	308,51



# HAZIRLIK

## DYNAMIC PREP



**SEBZE PARÇALAMA MAKİNELERİ**  
VEGETABLE CUTTERS



**HUMUS MAKİNELERİ**  
HUMMUS MACHINES



**TABAK KAPATMA MAKİNESİ**  
MEAL SEALING



**SET ÜSTÜ MİKSERLER**  
STAND MIXERS



**HAMUR AÇMA MAKİNESİ**  
DOUGH ROLLER MACHINES



Hız kontrolü ile  
yüksek verimde çalışma  
High efficiency  
with speed control



8 / 10 / 13 lt  
Kazan kapasitesi  
8 / 10 / 13 lt  
Capacity options



**TR**

- Şeffaf kapak
- Çalışma sırasında malzeme eklemek için açılabilen ekleme kapağı
- Güçlü alüminyum gövde yapısı
- Kapaktaki mikro anahtar sistemi ile güvenli çalışma
- Paslanmaz çelik kazan
- Daha iyi bir ısı yalıtımı için ayrılmış motor ve hazne
- Sürekli çalışma için yüksek verimli havalandırılmalı motor
- Sabitleyicili hız kontrol sistemi

**EN**

- See-through lid
- Lid with opening to add ingredients during operation
- Strong aluminium body construction
- Safe operations ensured by a system of micro switches on the lid
- S/S AISI 304 bowl
- Detached motor and bowl for a better thermal insulation
- High efficiency ventilated motor for continuous operation
- Speed control with stabilizer



**Omk.SZP01.E11.0801.Z5F**

**8** Lt kapasite  
8 Lt capacity

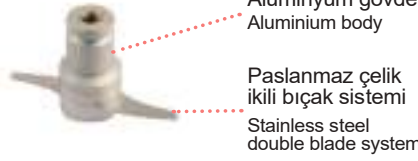

KOD / CODE	RENK / COLOR						€
Omk.SZP01.E11.0801.Z5F	● Siyah / Black	380x510x390 mm	19,5 kg	230 / 50-60 V/Hz -1,20 kW	400x520x415 mm	21,0 kg	571,93
Omk.SZP01.E11.0803.Z5F	● Kırmızı / Red	380x510x390 mm	19,5 kg	230 / 50-60 V/Hz -1,20 kW	400x520x415 mm	21,0 kg	571,93
Omk.SZP01.E11.0808.Z5F	● Gri / Gray	380x510x390 mm	19,5 kg	230 / 50-60 V/Hz -1,20 kW	400x520x415 mm	21,0 kg	571,93



**Omk.SZP01.E11.1003.Z5F**

**10** Lt kapasite  
10 Lt capacity

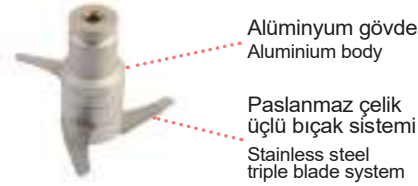

KOD / CODE	RENK / COLOR						€
Omk.SZP01.E11.1001.Z5F	● Siyah / Black	380x510x410 mm	19,5 kg	230 / 50-60 V/Hz -1,20 kW	400x520x415 mm	21,0 kg	602,90
Omk.SZP01.E11.1003.Z5F	● Kırmızı / Red	380x510x410 mm	19,5 kg	230 / 50-60 V/Hz -1,20 kW	400x520x415 mm	21,0 kg	602,90
Omk.SZP01.E11.1008.Z5F	● Gri / Gray	380x510x410 mm	19,5 kg	230 / 50-60 V/Hz -1,20 kW	400x520x415 mm	21,0 kg	602,90



**Omk.SZP01.E11.1308.Z5F**

**13** Lt kapasite  
13 Lt capacity

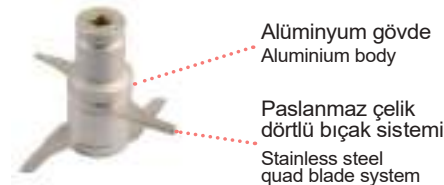

KOD / CODE	RENK / COLOR						€
Omk.SZP01.E11.1301.Z5F	● Siyah / Black	380x510x460 mm	19,5 kg	230 / 50-60 V/Hz -1,20 kW	400x520x470 mm	21,0 kg	633,81
Omk.SZP01.E11.1303.Z5F	● Kırmızı / Red	380x510x460 mm	19,5 kg	230 / 50-60 V/Hz -1,20 kW	400x520x470 mm	21,0 kg	633,81
Omk.SZP01.E11.1308.Z5F	● Gri / Gray	380x510x460 mm	19,5 kg	230 / 50-60 V/Hz -1,20 kW	400x520x470 mm	21,0 kg	633,81



Omk.HMS11.E11.1300.Z5F

13 Lt  
13 lt kapasite  
13 lt capacity

**TR**

- Şeffaf kapak
- Çalışma sırasında malzeme eklemek için açılabilen ekleme kapağı
- Kapaktaki mikro anahtar sistemi ile güvenli çalışma
- Paslanmaz çelik kazan
- Daha iyi bir ısı yalıtımı için ayrılmış motor ve hazne
- Sürekli çalışma için yüksek verimli havalandırılmalı motor
- Sabitleyicili hız kontrol sistemi

**EN**

- See-through lid
- Lid with opening to add ingredients during operation
- Safe operations ensured by a system of micro switches on the lid
- S/S AISI 304 bowl
- Detached motor and bowl for a better thermal insulation
- High efficiency ventilated motor for continuous operation
- Speed control with stabilizer

KOD / CODE						
Omk.HMS11.E11.1300.Z5F	320x550x420 mm	38,0 kg	230 / 50-60 V/HZ - 2,2 kW	345x580x425 mm	39,0 kg	1.798,24



Omk.HMS21.E11.1300.Z5F

13 Lt  
13 lt kapasite  
13 lt capacity



KOD / CODE						
Omk.HMS21.E11.1300.Z5F	545x440x1050 mm	40,0 kg	230 / 50-60 V/HZ - 2,2 kW	700x530x1200 mm	55,0 kg	1.965,61



Max kapak kalınlığı: 0,5mm  
Max sealing cover thickness: 0,5mm



Max mühürleme ebadı: 180x260 mm  
Max sealing size: 180x260mm

**TR**

İlk andaki kadar taze. Yiyecek ve içeceklerinizi mühürlü tabaklarda güvenle taşımanızı sağlar. Paket servisi yapmak artık kolay ve rahat

Make it safer, make it fresher. Carry and keep your takeaways in sealed safe boxes



Omk.TBK01.E15.0010.Z5F



Omk.TBK01.KLP.0100.000  
250 GR



Omk.TBK01.KLP.0101.000  
500 GR



Omk.TBK01.KLP.0102.000  
750 GR

KOD / CODE						
Omk.TBK01.E15.0010.Z5F	310x570x240 mm	24,5 kg	230 / 50-60 V/HZ - 0,75 kW	330x580x260 mm	26,5 kg	707,08
Omk.TBK01.KLP.0100.000	210x300x10 mm	1,0 kg	-	220x310x20 mm	1,5 kg	55,82
Omk.TBK01.KLP.0101.000	210x300x10 mm	1,0 kg	-	220x310x20 mm	1,5 kg	55,82
Omk.TBK01.KLP.0102.000	210x300x10 mm	1,0 kg		220x310x20 mm	1,5 kg	55,82

2

**HAZIRLIK**  
DYNAMIC PREP



Kazan ve aparatların çıkarılması ve kolay temizlenmesi için hareketli başlık

Liftable head for bowl and tools removal and easy cleaning

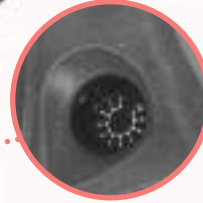

Hız kontrollü motor  
Motor with speed control

**TR**

- Kazan ve aparatların çıkarılması ve kolay temizlenmesi için hareketli başlık
- Çıkarılabilir 7 lt kazan
- Paslanmaz çelik kazan ve aksesuarlar
- Hız kontrollü motor
- Emniyet switchi sayesinde güvenli kullanım

**EN**

- Liftable head for bowl and tools removal and easy claeing
- Removable 7 lt bowl
- Stainless Steel bowl and tools
- Motor with speed control
- Safety microswitch on the head

KOD / CODE	RENK / COLOR						
Omk.SUM01.E11.0101.Z5F	● Siyah / Black	250x430x460 mm	16,0 kg	230 / 50-60 V/HZ -0,35 kW	280x450x460 mm	17,5 kg	887,58
Omk.SUM01.E11.0103.Z5F	● Kırmızı / Red	250x430x460 mm	16,0 kg	230 / 50-60 V/HZ -0,35 kW	280x450x460 mm	17,5 kg	887,58
Omk.SUM01.E11.0108.Z5F	● Gri / Gray	250x430x460 mm	16,0 kg	230 / 50-60 V/HZ -0,35 kW	280x450x460 mm	17,5 kg	887,58

**HAMUR AÇMA MAKİNESİ**  
DOUGH ROLLER MACHINES



**Omk.HMA01.E11.0030.Z5F**



**Omk.HMA01.E11.0040.Z5F**



KOD / CODE						€
Omk.HMA01.E11.0030.Z5F	410x430x710 mm	33,0 kg	230 / 50-60 V/HZ-0,37 kW	460x560x770 mm	40,0 Kg	1.665,41
Omk.HMA01.E11.0040.Z5F	510x460x730 mm	40,0 kg	230 / 50-60 V/HZ-0,37 kW	560x560x870 mm	46,0 Kg	1.769,83



**Omk.HMA11.E11.0030.Z5F**



**Omk.HMA11.E11.0040.Z5F**



KOD / CODE						€
Omk.HMA11.E11.0030.Z5F	410x430x710 mm	33,0 kg	230 / 50-60 V/HZ-0,37 kW	460x560x770 mm	40,0 kg	1.661,69
Omk.HMA11.E11.0040.Z5F	510x460x730 mm	40,0 kg	230 / 50-60 V/HZ-0,37 kW	560x560x870 mm	46,0 kg	1.763,77



# PIŞİRME COOK



**IZGARALAR**  
GRILLS



**BURGER**  
BURGER



**MAKARNA HAŞLAMA**  
PASTA COOKER



**FRİTÖZLER**  
FRYERS



**OCAKLAR**  
COOKERS



**İNDÜKSİYON OCAKLAR**  
INDUCTION COOKERS



**SOSİS KIZARTMA**  
HOT DOG GRILL



**SOSİS ISITMA**  
HOT DOG WARMER



**SOSİS HAŞLAMA**  
HOT DOG BOILED



**SOSİS DİNLENDİRME**  
HOT DOG DISPLAY CASE



**SALAMANDER**  
SALAMENDER



**BENMARİ**  
BAINMARIE



**PATATES DİNLENDİRME**  
CHIPS SCUTTLE UNIT



**EKMEK KIZARTMA**  
CONVEYOR TOASTER



**MANUEL LOKMA MAKİNESİ**  
MANUAL DOUGHNUT MACHINE

Kompakt mutfaklar için işlevsel ızgaralar...  
Omake elektrikli ve gazlı ızgaralar kompakt mutfak alanları ve mobil üniteler için tasarlanmış cihazlardır.

Functional griddles for compact areas...  
Omake electrical and gas griddles are useful for compact kitchen areas and mobile kitchens.



DKP çelik veya döküm pişirme yüzeyi  
Steel or cast plate cooking plate surface



**TR**

- Elektrikli veya gazlı modeller
- Manuel model
- Dkp çelik veya döküm pişirme yüzeyi
- Gazlı modeller için piezo çakmak ile ateşleme
- Çıkarılabilir yağ toplama haznesi
- Kolay çıkarılabilir pişirme yüzeyi
- Farklı ebatlarda model seçenekleri
- Paslanmaz çelik rezistanlar ve brülör ile homojen ısı dağılımı
- Farklı sıcaklık ayarında çalıştırma
- Seri pişirmelerde yüksek performans
- Gösterge ve sinyal lambaları
- Paslanmaz çelik gövde
- Gıda ile temasa uygun pişirme yüzeyi ve gövde

**EN**

- Electric or gas operated options
- Manual model
- Steel or cast plate cooking plate surface
- Piezo ignition for gas models
- Removable oil tray
- Easily removable cooking plate
- Available in different sizes
- Stainless steel heaters and burners provides homogeneous heating
- Operation with desired heating temperature
- High performance during dynamic operation
- Power ON and Ready-to-Cook LED indicators
- Stainless steel body
- Cooking plates and body suitable for food contact

## ELEKTRİKLİ IZGARALAR - DKP PLEYT

ELECTRIC GRILLS - STEEL PLATE



Omk.IZG02.E11.0030.Z5F

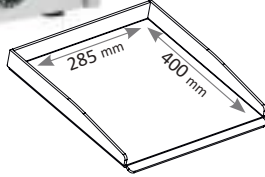

Omk.IZG02.E11.0040.Z5F

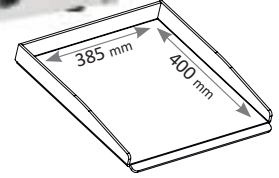

KOD / CODE						€
Omk.IZG02.E11.0030.Z5F	300x480x230 mm	12,5 kg	230 / 50-60 V/Hz - 1,75 kW	345x495x255 mm	13,5 kg	136,19
Omk.IZG02.E11.0040.Z5F	400x480x230 mm	16,0 kg	230 / 50-60 V/Hz - 3,50 kW	445x495x255 mm	17 kg	182,48



Omk.IZG02.E11.0050.Z5F

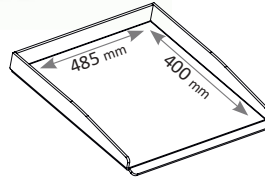

Omk.IZG02.E11.0060.Z50

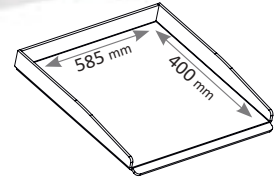

KOD / CODE						€
Omk.IZG02.E11.0050.Z5F	500x480x230 mm	19,5 kg	230 / 50-60 V/Hz - 3,50 kW	545x595x255 mm	20,5 kg	201,86
Omk.IZG02.E11.0060.Z50	600x480x230 mm	23,5 kg	230 / 50-60 V/Hz - 5,25 kW	645x495x255 mm	25,0 kg	260,84



Omk.IZG02.E11.0070.Z50

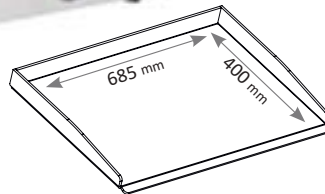

KOD / CODE						€
Omk.IZG02.E11.0070.Z50	700x480x230 mm	26,5 kg	230 / 50-60 V/Hz - 5,25 kW	745x495x255mm	28,0 kg	275,89



Omk.IZG02.N11.0030.000



Omk.IZG02.N11.0040.000



KOD / CODE						
Omk.IZG02.N11.0030.000	300x485x230 mm	11,5 kg	NG / 21 mbar / 2,7 kW	345x495x255 mm	12,5 kg	162,43
Omk.IZG02.N11.0040.000	400x485x230 mm	14,0 kg	NG / 21 mbar / 2,7 kW	445x495x255 mm	15,0 kg	174,29



Omk.IZG02.N11.0050.000



Omk.IZG02.N11.0060.000



KOD / CODE						
Omk.IZG02.N11.0050.000	500x485x230 mm	17,0 kg	NG / 21 mbar / 2,7 kW	545x495x255 mm	18,0 kg	190,58
Omk.IZG02.N11.0060.000	600x485x230 mm	20,5 kg	NG / 21 mbar / 5,4 kW	645x495x255 mm	22,0 kg	282,43



Omk.IZG02.N11.0070.000



KOD / CODE						
Omk.IZG02.N11.0070.000	700x485x230 mm	23,0 kg	NG / 21 mbar / 5,4 kW	745x495x255 mm	24,5 kg	295,82

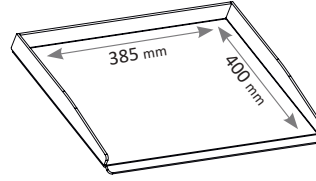

**Omk.IZG02.E11.2040.Z5F**



KOD / CODE						
Omk.IZG02.E11.2040.Z5F	400x480x230 mm	21,0 kg	230 / 50-60 V/HZ - 3,5 kW	445x495x255 mm	22,0 kg	262,22

3

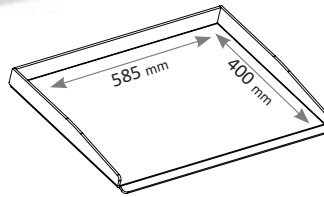

**Omk.IZG02.E11.2060.Z50**

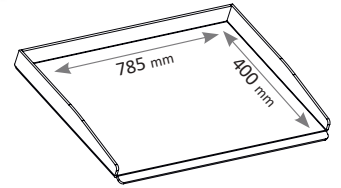

**Omk.IZG02.E11.2080.Z50**



KOD / CODE						
Omk.IZG02.E11.2060.Z50	600x480x230 mm	28,5 kg	230 / 50-60 V/HZ - 5,25 kW	645x495x255 mm	30,0 kg	375,60
Omk.IZG02.E11.2080.Z50	800x480x230 mm	37,5 kg	230 / 50-60 V/HZ - 5,25 kW	845x495x255 mm	38,0 kg	439,97

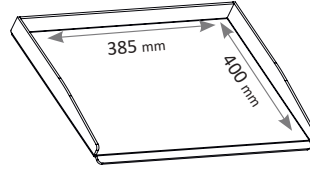

**Omk.IZG02.N11.2040.000**

**MANUEL**  
MANUAL

KOD / CODE						
Omk.IZG02.N11.2040.000	400x485x230 mm	19,0 kg	NG / 21 mbar / 2,7 kW	445x495x255 mm	20,0 kg	254,72

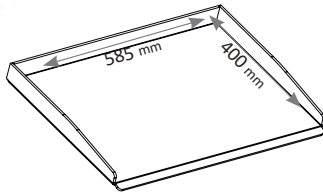

**Omk.IZG02.N11.2060.000**

**MANUEL**  
MANUAL

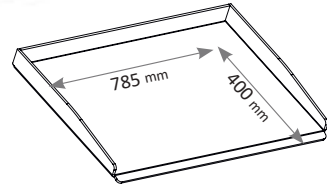

**Omk.IZG02.N11.2080.000**

**MANUEL**  
MANUAL

KOD / CODE						
Omk.IZG02.N11.2060.000	600x485x230 mm	26,0 kg	NG / 21 mbar / 5,4 kW	645x495x255 mm	27,5 kg	397,38
Omk.IZG02.N11.2080.000	800x485x230 mm	33,0 kg	NG / 21 mbar / 8,1 kW	845x495x255 mm	34,5 kg	539,18

3

**PIŞİRME**  
COOK



**TR**

- Üst ve alt ızgara pleyti ayrı ayrı kontrol edilebilir.
- Çelik Alt ve Üst Plakalar.
- Yapışmaz ızgara yüzeyi için teflon film kaplı üst plaka.
- Profesyonel kullanım için uygun.
- Program sona erdikten sonra pleyt ızgara otomatik açılır.
- Ayarlanabilir Üst pleyt ızgara yüksekliği.
- Ayarlanabilir 6 farklı zamanlama programı.
- Üst plaka için maks 250 °C , alt plaka için maksimum 300 °C çalışma sıcaklığı.

**EN**

- The top and bottom grill plates can be controlled separately.
- Steel top and bottom plates.
- Teflon film-coated top plate for a non-stick grill surface.
- Suitable for professional use.
- The grill plate automatically opens after the program finishes.
- Adjustable height for the top grill plate.
- Adjustable with 6 different timing programs.
- Maximum operating temperature of 250°C for the top plate, and 300°C for the bottom plate.

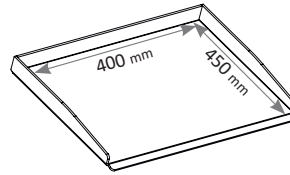

**Omk.BRG01.E15.0001.U50**



KOD / CODE						
Omk.BRG01.E15.0001.U50	400x720x425 mm	65,0 kg	400/ 50-60 V/HZ - 6,0 kW	450x850x560 mm	74,0 kg	1.532,87

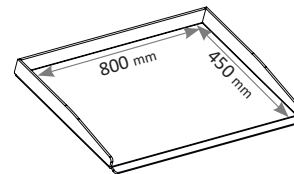

**Omk.BRG01.E25.0001.U50**



KOD / CODE						
Omk.BRG01.E25.0001.U50	800x720x425 mm	125,0 kg	400 / 50-60 V/HZ - 2x6 kW	850x850x560 mm	145,0 kg	3.238,15



**TR**

- 50-190°C arasında ayarlanabilir termostat
- Emniyet termostatu
- Hızlı ısınan ve kolay temizlenebilen sistem
- Paslanmaz çelik sağlam yapı
- Tahliye vanalı ve çıkarılabilir kazan seçenekleri
- Paslanmaz çelik rezistanslar ile homojen ısı dağılımı
- Farklı sıcaklık ayarında çalıştırma
- Seri pişirmelerde yüksek performans
- Gösterge ve sinyal lambası
- Paslanmaz çelik gövde
- Gıda ile temasa uygun pişirme yüzey

**EN**

- Adjustable thermostat between 50-190°C
- Safety thermostat
- System that heats up quickly and is easy to clean
- Stainless steel solid structure
- Removable and with drain valve boiler options
- Homogeneous heat distribution with stainless steel resistors
- Operating at different temperature setting
- High performance at series cooking
- Indicator and signal bulb
- Stainless steel body
- Cooking surface suitable for food contact



Omk.MKR01.E11.0001.Z5F



10 lt kapasite  
10 lt capacity

MANUEL  
MANUAL



ELECTRIC

KOD / CODE						
Omk.MKR01.E11.0001.Z5F	270x495x375 mm	10,0 kg	230 / 50-60 V/HZ - 3,2 kW	310x520x440 mm	10,5 kg	285,51



Hızlı ısınan ve kolay temizlenebilen sistem  
Quickly heating and extremely easy to clean



Tahliye musluğu sayesinde kolay boşaltım  
Easy emptying with drain valve



Paslanmaz çelik sağlam yapı  
Stainless steel robust structure



**TR**

- 50-190°C arasında ayarlanabilir termostat
- Emniyet termostatu
- Hızlı ısınan ve kolay temizlenebilen sistem
- Paslanmaz çelik sağlam yapı
- Tahliye vanalı ve çıkarılabilir kazan seçenekleri
- Yağın kolayca boşaltılması için tahliye vanası
- Paslanmaz çelik rezistanslar ile homojen ısı dağılımı
- Farklı sıcaklık ayarında çalıştırma
- Seri pişirmelerde yüksek performans
- Gösterge ve sinyal lambası
- Paslanmaz çelik gövde
- Gıda ile temasa uygun pişirme yüzeyi

**EN**

- Adjustable thermostat of 50-190°C
- Safety thermostat
- Quickly heating and extremely easy to clean
- Stainless steel robust structure
- Fryer with drain valve and removable frying tank options
- Drain valve for easy draining of the oil
- Stainless steel heaters
- Operation with desired heating temperature
- High performance during dynamic operation
- Power ON and Ready-to-Cook LED indicator
- Stainless steel body
- Suitable for food contact



Omk.FRT21.E11.0030.Z5F

TAHLİYESİZ - 3 LT  
WITHOUT DRAIN VALVE - 3 LT ELECTRIC 230 V



Omk.FRT21.E21.0030.Z5F

TAHLİYESİZ - 3+3 LT  
WITHOUT DRAIN VALVE - 3+3 LT ELECTRIC 230 V

KOD / CODE						
Omk.FRT21.E11.0030.Z5F	270x445x270 mm	4,5 kg	230 / 50-60 V/HZ - 2,50 kW	310x480x370 mm	5,0 kg	189,42
Omk.FRT21.E21.0030.Z5F	535x445x270 mm	7,5 kg	230 / 50-60 V/HZ - 2x2,5 kW	570x480x370 mm	8,0 kg	364,26

3



Omk.FRT21.E11.0050.Z5F

TAHLİYESİZ - 5 LT  
WITHOUT DRAIN VALVE - 5 LT ELECTRIC 230 V



Omk.FRT21.E21.0050.Z5F

TAHLİYESİZ - 5x5 LT  
WITHOUT DRAIN VALVE - 5x5 LT ELECTRIC 230 V

KOD / CODE						
Omk.FRT21.E11.0050.Z5F	270x445x320 mm	5,0 kg	230 / 50-60 V/HZ - 2,75 kW	310x480x420 mm	5,5 kg	203,34
Omk.FRT21.E21.0050.Z5F	535x445x320 mm	9,0 kg	230 / 50-60 V/HZ - 2x2,75 kW	570x480x420 mm	9,5 kg	391,43

PIŞIRME  
COOK



**Omk.FRT21.E11.0080.Z5F**

TAHLİYESİZ - 8 LT  
WITHOUT DRAIN VALVE - 8 LT ELECTRIC 230 V



**Omk.FRT21.E21.0080.Z5F**

TAHLİYESİZ - 8+8 LT  
WITHOUT DRAIN VALVE - 8+8 LT ELECTRIC 230 V

KOD / CODE						€
Omk.FRT21.E11.0080.Z5F	270x445x345 mm	5,0 kg	230 / 50-60 V/HZ - 3,00 kW	310x480x440 mm	5,5 kg	231,79
Omk.FRT21.E21.0080.Z5F	535x445x345 mm	9,0 kg	230 / 50-60 V/HZ - 2x3 kW	570x480x440 mm	9,5 kg	432,75



**Omk.FRT12.E11.0100.Z5F**

TAHLİYESİZ - 10 LT  
WITHOUT DRAIN VALVE - 10 LT ELECTRIC 230 V



**Omk.FRT12.E11.0101.Z5F**

TAHLİYELİ - 10 LT  
WITH DRAIN VALVE - 10 LT ELECTRIC 230 V

KOD / CODE						€
Omk.FRT12.E11.0100.Z5F	270x445x375 mm	6,0 kg	230 / 50-60 V/HZ - 3,20 kW	310x480x440 mm	6,5 kg	221,00
Omk.FRT12.E11.0101.Z5F	270x495x375 mm	6,5 kg	230 / 50-60 V/HZ - 3,2 kW	310x520x440 mm	7,0 kg	294,67









Omk.FRT12.E21.0100.Z5F

 TAHLİYESİZ - 10\*10 LT  
WITHOUT DRAIN VALVE - 10\*10 LT  230 V



Omk.FRT12.E21.0101.Z5F

 TAHLİYELİ - 10\*10 LT  
WITH DRAIN VALVE - 10\*10 LT  230 V

KOD / CODE						
Omk.FRT12.E21.0100.Z5F	535x445x375 mm	12,0 kg	230 / 50-60 V/HZ - 2x3,2 kW	570x480x440 mm	12,5 kg	412,24
Omk.FRT12.E21.0101.Z5F	535x495x375 mm	13,0 kg	230 / 50-60 V/HZ - 2x3,2 kW	570x520x440mm	13,5 kg	551,40

3

**PIŞIRME**  
COOK





**TR**

Kompakt mutfaklar için işlevsel ocaklar...  
Omake elektrikli ve gazlı ocaklar kompakt mutfak alanları ve mobil üniteler için verimli kullanım sağlar.

**EN**

Functional cookers for compact areas...  
Omake electrical and gas cookers are useful for compact kitchen areas and mobile kitchens.



Kademeli sıcaklık ayarı  
Steps of temperature heating

**TR**

- Elektrikli veya gazlı modeller
- Tekli ve çiftli model seçeneği
- Paslanmaz çelik preslenmiş üst tabla
- Farklı sıcaklık ayarında çalıştırma
- Seri pişirmelerde yüksek performans
- Gösterge ve sinyal lambaları
- Paslanmaz çelik gövde

**EN**

- Electric or gas operated options
- Single and double model options
- Stainless steel body pressed top
- Operation with desired heating temperature
- High performance during dynamic operation
- Power ON and Ready-to-Cook indicators
- Stainless steel body





**Omk.OCK02.E11.0001.Z5F**



**Omk.OCK02.E21.0001.Z50**



KOD / CODE						€
Omk.OCK02.E11.0001.Z5F	270x330x165 mm	3,5 kg	230 / 50-60 V/HZ - 2 kW	310x365x200 mm	4,0 kg	91,75
Omk.OCK02.E21.0001.Z50	530x330x165 mm	6,5 kg	230 / 50-60 V/HZ - 4 kW	565x365x200 mm	7,5 kg	160,08

**LPG OCAKLAR**  
LPG COOKERS



**Omk.OCK02.L11.0001.000**



**Omk.OCK02.L21.0001.000**



KOD / CODE						€
Omk.OCK02.L11.0001.000	270x360x170 mm	5,0 kg	L / 30 mbar / 2,6 kW	305x385x195 mm	5,5 kg	146,89
Omk.OCK02.L21.0001.000	530x360x170 mm	9,5 kg	L / 30 mbar / 5,2 kW	565x385x195 mm	10,5 kg	264,10



**Omk.OCK02.N11.0001.000**



**Omk.OCK02.N21.0001.000**



KOD / CODE						
Omk.OCK02.N11.0001.000	270x360x170 mm	5,0 kg	NG / 50-60 V/HZ - 2,6 kW	305x385x195 mm	5,5 kg	148,32
Omk.OCK02.N21.0001.000	530x360x170 mm	9,5 kg	NG / 50-60 V/HZ - 4,5 kW	565x385x195 mm	10,5 kg	264,05



**Omk.OCK03.N11.0001.000**



**Omk.OCK03.N21.0001.000**



KOD / CODE						
Omk.OCK03.N11.0001.000	370x435x210 mm	11,0 kg	NG / 21 mbar / 5,2 kW	455x405x225 mm	11,5 kg	186,50
Omk.OCK03.N21.0001.000	710x435x210 mm	19,0 kg	NG / 21 mbar / 5,2 kW	740x455x225 mm	20,0 kg	339,38



Elektronik zaman ayarı  
Electronic timer



Dijital kontrol paneli ile kullanım kolaylığı  
Easy operation with digital control panel

Omaka indüksiyon pişiriciler mutfaklarınızda hızlı, güvenilir ve verimli kullanım sağlar

Omaka induction cookers provides quick, reliable and efficient cooking process in your kitchens

**TR**

- Seramik cam pişirme yüzeyi
- Isıtma veya sıcak tutma özelliği bulunmamaktadır
- Tekli ve çiftli model seçeneği
- Çok kısa sürede pişirme imkânı ile enerji tasarrufu
- Dijital kontrol paneli ile kullanım kolaylığı
- Elektronik zaman ayarı
- Farklı sıcaklık ayarında çalıştırma
- Seri pişirmelerde yüksek performans
- Paslanmaz çelik gövde

**EN**

- Vitro -ceramic glass cooking surface
- No heating or keeping warm feature
- Single and double model options
- Energy saving with the possibility of cooking in sa very short time
- Easy operation with digital control panel
- Electronic timer
- Operation with desired heating temperature
- High performance during dynamic operation
- Stainless steel body





**Omk.IND11.115.1800.Z5F**  
1800 W



**Omk.IND11.115.2000.Z5F**  
2000 W



**Omk.IND11.115.2500.Z5F**  
2500 W



**Omk.IND11.115.3500.Z5F**  
3500 W



**Omk.IND11.115.5000.Z50**  
5000 W

KOD / CODE						
Omk.IND11.115.1800.Z5F	350x450x130 mm	6,5 kg	230 / 50-60 V/HZ - 1,8 kW	480x390x165 mm	7,0 kg	465,19
Omk.IND11.115.2000.Z5F	350x450x130 mm	6,5 kg	230 / 50-60 V/HZ - 2,0 kW	480x390x165 mm	7,0 kg	466,93
Omk.IND11.115.2500.Z5F	350x450x130 mm	7,0 kg	230 / 50-60 V/HZ - 2,5 kW	480x390x165 mm	7,5 kg	481,38
Omk.IND11.115.3500.Z5F	400x495x130 mm	8,0 kg	230 / 50-60 V/HZ - 3,5 kW	530x440x165 mm	9,0 kg	486,23
Omk.IND11.115.5000.Z50	400x495x130 mm	8,0 kg	230 / 50-60 V/HZ - 5 kW	530x440x165 mm	9,0 kg	625,96



Omk.IND11.I25.1800.Z5F  
2x1800 W



Omk.IND11.I25.2000.Z5F  
2x2000 W



Omk.IND11.I25.2500.Z5F  
2x2500 W



Omk.IND11.I25.3500.Z5F  
2x3500 W



Omk.IND11.I25.5000.Z50  
2x5000 W

3

PIŞİRME  
COOK

KOD / CODE						€
Omk.IND11.I25.1800.Z5F	700x450x130 mm	12,5 kg	230 / 50-60 V/HZ - 2x1,8 kW	735x485x165 mm	13,5 kg	900,35
Omk.IND11.I25.2000.Z5F	700x450x130 mm	12,5 kg	230 / 50-60 V/HZ - 2x2 kW	735x485x165 mm	13,5 kg	903,21
Omk.IND11.I25.2500.Z5F	700x450x130 mm	13,0 kg	230 / 50-60 V/HZ - 2x2,5 kW	735x485x165 mm	14,0 kg	932,09
Omk.IND11.I25.3500.Z5F	800x495x130 mm	15,0 kg	230 / 50-60 V/HZ - 2x3,5 kW	830x530x165 mm	16,0 kg	941,50
Omk.IND11.I25.5000.Z50	800x495x130 mm	15,0 kg	230 / 50-60 V/HZ - 2x5 kW	830x530x165 mm	16,0 kg	1.220,45



Omk.IND21.I25.1800.Z5F  
2x1800 W



Omk.IND21.I25.2000.Z5F  
2x2000 W



Omk.IND21.I25.2500.Z5F  
2x2500 W



Omk.IND21.I25.3500.Z5F  
2x3500 W



Omk.IND21.I25.5000.Z50  
2x5000 W

KOD / CODE							
Omk.IND21.I25.1800.Z5F	350x785x130 mm	12,5 kg	230 / 50-60 V/HZ	- 2x1,8 kW	805x390x165 mm	13,5 kg	886,54
Omk.IND21.I25.2000.Z5F	350x785x130 mm	12,5 kg	230 / 50-60 V/HZ	- 2x2 kW	805x390x165 mm	13,5 kg	889,39
Omk.IND21.I25.2500.Z5F	350x780x130 mm	13,0 kg	230 / 50-60 V/HZ	- 2x2,5 kW	805x390x165 mm	14 kg	921,89
Omk.IND21.I25.3500.Z5F	400x925x130 mm	15,0 kg	230 / 50-60 V/HZ	- 2x3,5 kW	960x440x165 mm	16,0 kg	939,98
Omk.IND21.I25.5000.Z50	400x925x130 mm	15,0 kg	230 / 50-60 V/HZ	- 2 kW	960x440x165 mm	16,0 kg	1.218,90



**Omk.IND02.115.1800.Z5F**  
**1800W**



**Omk.IND02.115.2000.Z5F**  
**2000W**



**Omk.IND02.115.2500.Z5F**  
**2500W**



**Omk.IND02.115.3500.Z5F**  
**3500W**



**Omk.IND02.115.5000.Z50**  
**5000W**

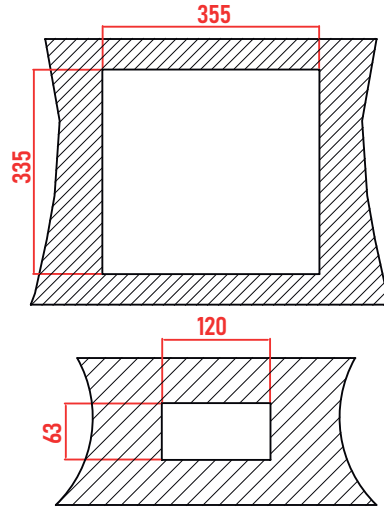

3

PIŞİRME  
COOK

KOD / CODE						€
Omk.IND02.115.1800.Z5F	380x360x125 mm	7,0 kg	230 / 50-60 V/HZ - 1,8 kW	435x375x170 mm	7,5 kg	491,03
Omk.IND02.115.2000.Z5F	380x360x125 mm	7,0 kg	230 / 50-60 V/HZ - 2,0 kW	435x375x170 mm	7,5 kg	492,46
Omk.IND02.115.2500.Z5F	380x360x125 mm	7,0 kg	230 / 50-60 V/HZ - 2,5 kW	435x375x170 mm	7,5 kg	492,46
Omk.IND02.115.3500.Z5F	400x400x130 mm	7,5 kg	230 / 50-60 V/HZ - 3,5 kW	455x415x170 mm	8,0 kg	509,62
Omk.IND02.115.5000.Z50	400x400x130 mm	7,5 kg	230 / 50-60 V/HZ - 5,0 kW	455x415x170 mm	8,0 kg	649,10



KOD / CODE						
Omk.IND25.I15.3500.Z5F	350x450x210 mm494	8,0 kg	230 / 50-60 V/HZ - 3,5 kW	380x480x230 mm	9,0 kg	501,96



KOD / CODE						
Omk.IND25.I15.5000.Z50	350x450x210 mm	8,0 kg	230 / 50-60 V/HZ - 5,0 kW	380x480x230 mm	9,0 kg	643,24

3

PIŞİRME  
COOK

**TR**

- Kolay kullanım
- Profesyonel kullanım için ideal
- Eşit ısı dağılımı
- Ayır ayarlanabilir iki termostat
- Ayır ayır ayarlanabilir ısıtma bölgeleri
- 2 ısıtma bölgesi
- 2 çalışma kontrol ışıkları
- Açma / kapama düğmesi
- Kolay temizlenebilir

**EN**

- Easy to use
- Excellently suited for use in professional kitchens
- Equal heat distribution
- Two separately adjustable thermostats
- Heating zones can be adjusted separately
- 2 Heating zones
- 2 Operating control lights
- On/off switch
- Easy to clean



**Omk.SSK01.E11.0005.Z5F**



**Omk.SSK01.E11.0007.Z5F**



KOD / CODE						€
Omk.SSK01.E11.0005.Z5F	585x295x185 mm	6,0 kg	230 / 50-60 V/HZ - 1,00 kW	630x310x210 mm	7,0 kg	306,15
Omk.SSK01.E11.0007.Z5F	585x365x185 mm	7,5 kg	230 / 50-60 V/HZ - 1,40 kW	630x380x210 mm	8,5 kg	366,21



**Omk.SSK01.E11.0009.Z5F**



**Omk.SSK01.E11.0011.Z5F**



KOD / CODE						€
Omk.SSK01.E11.0009.Z5F	585x435x185 mm	9,0 kg	230 / 50-60 V/HZ - 1,80 kW	630x450x210 mm	10,0 kg	407,44
Omk.SSK01.E11.0011.Z5F	585x505x185 mm	10,0 kg	230 / 50-60 V/HZ - 2,20 kW	630x520x210 mm	11,00 kg	464,42

**TR**

- Profesyonel kullanıma uygun,
- Hızlı servis avantajı,
- Kolay kullanım ve hijyenik tasarım,
- Kademeli termostat,
- 3 farklı kademede ısıtma seçeneği,
- Paslanmaz Çelik yapı,
- Ayrı ayrı ayarlanabilir ısıtma bölgeleri

**EN**

- Suitable for professional use
- Fast service advantage
- User-friendly and hygienic design
- Incremental thermostat
- Three different heating settings
- Stainless steel construction
- Independently adjustable heating zones



**Omk.SSK11.E11.0005.Z5F**

**Omk.SSK11.E11.0007.Z5F**



KOD / CODE						€
Omk.SSK11.E11.0005.Z5F	585x295x185 mm	6,0 kg	230 / 50-60 V/HZ - 0,75 kW	630x310x210 mm	7,0 kg	348,26
Omk.SSK11.E11.0007.Z5F	585x365x185 mm	7,5 kg	230 / 50-60 V/HZ - 1,10 kW	630x380x210 mm	8,5 kg	414,13



**Omk.SSK11.E11.0009.Z5F**

**Omk.SSK11.E11.0011.Z5F**



KOD / CODE						€
Omk.SSK11.E11.0009.Z5F	585x435x185 mm	9,0 kg	230 / 50-60 V/HZ - 1,35 kW	630x450x210 mm	10,0 kg	461,17
Omk.SSK11.E11.0011.Z5F	585x505x185 mm	10,0 kg	230 / 50-60 V/HZ - 1,65 kW	630x520x210 mm	11,00 kg	523,95



Omk.SSH11.E11.0004.Z5F



**TR**

- Sosisleri ısıtmak ve sıcak tutmak için cam silindir
- Çıkarılabilir kapak
- Ayarlanabilir sıcaklık
- Güvenli denge için lastik ayaklar
- Güç kontrol ışığı
- Kolay kullanım
- Kolay temizlenebilir

**EN**

- Glass cylinder for warming and keeping sausages warm
- Removable lid
- Adjustable temperature
- Rubber feet for secure the stability
- Indicator lights
- Easy to use
- Easy to clean

3

PIŞİRME  
COOK



Omk.SSH01.E11.0001.Z5F



Omk.SSH02.E11.0004.Z5F



KOD / CODE						€
Omk.SSH11.E11.0004.Z5F	480x280x450 mm	7,0 kg	230 / 50-60 V/HZ - 0,75 kW	510x320x470 mm	7,5 kg	521,09
Omk.SSH01.E11.0001.Z5F	280x280x450 mm	5,0 kg	230 / 50-60 V/HZ - 0,30 kW	300x320x470 mm	5,5 kg	230,67
Omk.SSH02.E11.0004.Z5F	280x280x365 mm	3,5 kg	230 / 50-60 V/HZ - 0,30 kW	300x320x470 mm	4,0 kg	338,89



**TR**

- Sosisli sandviç ısıtma vitrini 2 seviyeli
- Maksimum sıcaklık: 85 °C
- Kolay kullanım
- Açma / kapama düğmesi
- Güç kontrol ışığı
- Ayarlanabilir termostat
- Şık ürün sunumu
- Kolay temizlenebilir

**EN**

- Hotdog warming display case with 2 levels
- Maximum temperature: 85 °C
- Easy to use
- On/off switch
- Indicator lights
- Adjustable thermostat
- Elegant presentation of goods
- Easy to clean



Omk.SSD01.E11.0001.Z5F



KOD / CODE						
Omk.SSD01.E11.0001.Z5F	410x480x680 mm	13,5 kg	230 / 50-60 V/Hz - 0,80 kW	440x510x700 mm	14,0 kg	349,43





**Omk.SLM01.E11.0001.Z5F**

-  Asansörsüz  
Without Elevator
-  Elektrik  
Electric
-  Manuel  
Manual



**Omk.SLM05.E11.0001.Z5F**

-  Asansörlü  
With Elevator
-  Elektrik  
Electric
-  Manuel  
Manual

KOD / CODE						€
Omk.SLM01.E11.0001.Z5F	595x350x315 mm	10,0 kg	230 / 50-60 V/HZ - 2,0 kW	630x390x340 mm	11,0 kg	239,38
Omk.SLM05.E11.0001.Z5F	655x495x545 mm	43,0 kg	230 / 50-60 V/HZ - 3,0 kW	695x540x660 mm	54,0 kg	788,80

**GAZLI SALAMANDER**  
GAS SALAMENDER



**Omk.SLM03.N11.0003.000**

-  Asansörsüz  
Without Elevator
-  Gaz  
Gas
-  Manuel  
Manual



**Omk.SLM07.N11.0003.000**

-  Asansörlü  
With Elevator
-  Gaz  
Gas
-  Manuel  
Manual

KOD / CODE						€
Omk.SLM03.N11.0003.000	775x425x475 mm	20,0 kg	NG / 21 mbar / 7,8 kW	800x445x510 mm	21,0 kg	659,43
Omk.SLM07.N11.0003.000	745x505x510 mm	35,0 kg	NG / 21 mbar / 7,8 kW	780x540x630 mm	46,0 kg	834,92



1/2

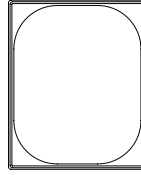

Omk.SUB01.E11.0001.Z5F  
1'Li

Omk.SUB02.E11.0001.Z5F  
1'Li



2x1/2

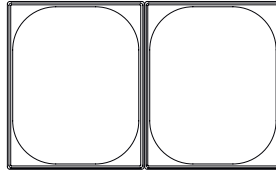

Omk.SUB01.E21.0001.Z5F  
2'Li

Omk.SUB02.E21.0001.Z5F  
2'Li



3x1/2

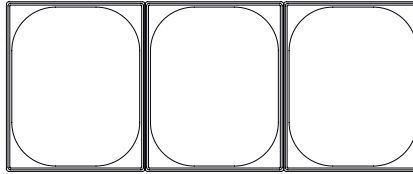

Omk.SUB01.E31.0001.Z5F  
3'Lü

Omk.SUB02.E31.0001.Z5F  
3'Lü

**TR**

- Elektrikli model seçeneği.
- Paslanmaz çelik gövde.
- Paslanmaz kapak.
- Farklı sıcaklık ayarında çalıştırma.
- Emniyet termostadı.
- Güç kontrol ışığı.
- Kolay temizlenebilir.
- Küvet ve küvet kapağı fiyatlara dahildir.

**EN**

- Electric model option.
- Stainless steel body.
- Stainless cover.
- Operation at different temperature setting.
- Safety thermostat.
- Power control light.
- Easy to clean.
- The bathtub and bathtub lid are included in the prices.

3

**PIŞIRME**  
COOK

KOD / CODE						
Omk.SUB01.E11.0001.Z5F	320x425x305 mm	6,0 kg	230 / 50-60 V/HZ - 0,80 kW	360x475x320 mm	6,5 kg	154,98
Omk.SUB01.E21.0001.Z5F	590x425x305 mm	9,5 kg	230 / 50-60 V/HZ - 0,80 kW	630x475x320 mm	10,5 kg	234,29
Omk.SUB01.E31.0001.Z5F	860x425x305 mm	12,5 kg	230 / 50-60 V/HZ - 1,10 kW	900x475x320 mm	14,0 kg	324,67
Omk.SUB02.E11.0001.Z5F	320x485x305 mm	7,0 kg	230 / 50-60 V/HZ - 0,80 kW	360x535x320 mm	7,5 kg	228,05
Omk.SUB02.E21.0001.Z5F	590x485x305 mm	10,5 kg	230 / 50-60 V/HZ - 0,80 kW	630x535x320 mm	11,5 kg	306,73
Omk.SUB02.E31.0001.Z5F	860x485x305 mm	13,5 kg	230 / 50-60 V/HZ - 1,10 kW	900x535x320 mm	14,5 kg	397,56



**Omk.PTD01.E11.0000.Z5F**



KOD / CODE						€
Omk.PTD01.E11.0000.Z5F	285x470x280 mm	3,5 kg	230 / 50-60 V/HZ - 0,75 kW	510x320x300 mm	4,0 kg	255,05



**Omk.PTD01.E11.0001.Z5F**



KOD / CODE						€
Omk.PTD01.E11.0001.Z5F	285x470x330 mm	4,0 kg	230 / 50-60 V/HZ - 0,75 kW	510x320x350 mm	4,5 kg	238,18



3







PIŞIRME  
COOK

**TR**

- 600 Dilim / Saat Kapasiteli
- Termostatik Kontrol
- Paslanmaz Çelik Gövde
- Paslanmaz çelik taşıyıcı tel
- Kolay Temizlenebilir Hijyenik ve Dayanıklılık

**EN**

- 600 Slices / Hour capacity.
- Thermostatic control.
- Stainless steel body.
- Stainless steel carrier wire.
- Easy to clean, hygienic and durable.

KOD / CODE						
Omk.EKM01.E11.0001.Z5F	490x460x400 mm	18,0 kg	230 / 50-60 V/HZ - 2,40 kW	500x470x410 mm	20,0 kg	609,34



**TR**

- Toplu tüketim için uygun kullanım
- Hijyenik ve uzun ömürlü
- Ergonomik tasarımı ile kullanım
- Manuel çalışma kolaylığı
- 7 kg hamur hazne kapasitesi
- Paslanmaz çelik gövde
- İzmir ve Saray lokma kalıbı.

**EN**





- Suitable use for mass consumption
- Hygienic and long-lasting
- Provides ease of use with its ergonomic design
- Works manually
- 7 kg dough bowl capacity
- Stainless steel body





3

PIŞIRME  
COOK

KOD / CODE					
Omk.LKM01.011.0001.000	650x470x470 mm	27,5 kg	670x510x590 mm	36,5 kg	949,68



# FIRIN OVEN



**ELEKTRİKLİ PİZZA FIRINLARI**  
ELECTRIC PIZZA OVENS



**KUMPIR FIRINLAR**  
POTATO BAKING OVENS



Yüksek sıcaklığa dayanıklı refrakter pişirme taşı

High temperature resistant refractory baking stone



400 °C maksimum çalışma derecesi

400 °C maximum working temperature



**TR**

İhtiyaç duyduğunuz işlevsel ve ergonomik çözümler için mutfakların yeni yardımcısı, Omake Pizza Fırınları.

**EN**

When you need functional and ergonomic solution for pizza baking Omake Pizza Oven line is your new partner in kitchen.

**TR**

- 1,2,3 katlı fırın seçenekleri
- Yüksek sıcaklığa dayanıklı refrakter pişirme taşı
- 400 °C maksimum çalışma derecesi
- Alt ve üst ayarlanabilir sıcaklık kontrolü
- İç aydınlatma
- Temperli kapak camı
- Farklı ebatlarda model seçenekleri
- Paslanmaz çelik rezistanslar ile homojen ısı dağılımı
- Farklı sıcaklık ayarında çalıştırma
- Seri pişirmelerde yüksek performans
- Paslanmaz çelik gövde
- Gıda ile temasa uygun pişirme taşı ve gövde

**EN**

- 1,2,3 deck options
- High temperature resistant refractory baking stone
- 400 °C maximum working temperature
- Lower and upper adjustable temperature control
- Inner lighting
- Tempered glass door
- Available in different sizes
- Stainless steel heaters and burners provides homogeneous baking
- Operation with desired heating temperature
- High performance during dynamic operation
- Stainless steel body
- Baking plates and body suitable for food contact



**Omk.FPZ01.E11.0401.Z5F**

1 x Ø39 Pizza kapasitesi  
1 x Ø39 Pizza capacity

1 Katlı 40 x 40  
1 Deck 40 x 40

Elektrikli  
Electric

Manuel  
Manual



**Omk.FPZ01.E21.0402.U50**

2 x Ø39 Pizza kapasitesi  
2 x Ø39 Pizza capacity

2 Katlı 40 x 40  
2 Deck 40 x 40

Elektrikli  
Electric

Manuel  
Manual



**Omk.FPZ01.E31.0403.U50**

3 x Ø39 Pizza kapasitesi  
3 x Ø39 Pizza capacity

3 Katlı 40 x 40  
3 Deck 40 x 40

Elektrikli  
Electric

Manuel  
Manual

KOD / CODE						
Omk.FPZ01.E11.0401.Z5F	640x600x330 mm	33 kg	230 / 50-60 V/HZ - 3 kW	660x620x480 mm	45 kg	593,00
Omk.FPZ01.E21.0402.U50	640x600x560 mm	57 kg	400 / 50-60 V/HZ - 6 kW	660x620x710 mm	71 kg	1.031,50
Omk.FPZ01.E31.0403.U50	640x600x800 mm	81 kg	400 / 50-60 V/HZ - 9 kW	660x620x950 mm	96 kg	1.706,64



**Omk.FPZ01.E11.0501.Z50**

4 x Ø25 Pizza kapasitesi  
4 x Ø25 Pizza capacity

1 Katlı 52 x 52  
1 Deck 52 x 52

Elektrikli  
Electric

Manuel  
Manual



**Omk.FPZ01.E21.0502.U50**

8 x Ø25 Pizza kapasitesi  
8 x Ø25 Pizza capacity

2 Katlı 52 x 52  
2 Deck 52 x 52

Elektrikli  
Electric

Manuel  
Manual



**Omk.FPZ01.E31.0503.U50**

12 x Ø25 Pizza kapasitesi  
12 x Ø25 Pizza capacity

3 Katlı 52 x 52  
3 Deck 52 x 52

Elektrikli  
Electric

Manuel  
Manual

KOD / CODE						
Omk.FPZ01.E11.0501.Z50	760x700x320 mm	45 kg	230 / 50-60 V/HZ - 3,9 kW	780x720x470 mm	59 kg	762,05
Omk.FPZ01.E21.0502.U50	760x700x560 mm	73,5 kg	400 / 50-60 V/HZ - 7,8 kW	780x720x710 mm	87,5 kg	1.466,85
Omk.FPZ01.E31.0503.U50	760x700x800 mm	104 kg	400 / 50-60 V/HZ - 11,7 kW	780x720x950 mm	119 kg	2.054,77



**Omk.FPZ01.E11.0601.Z50**

4 x Ø30 Pizza kapasitesi  
4 x Ø30 Pizza capacity

1 Katlı 62 x 62  
1 Deck 62 x 62

Elektrikli  
Electric

Manuel  
Manual



**Omk.FPZ01.E21.0602.U50**

8 x Ø30 Pizza kapasitesi  
8 x Ø30 Pizza capacity

2 Katlı 62 x 62  
2 Deck 62 x 62

Elektrikli  
Electric

Manuel  
Manual



**Omk.FPZ01.E31.0603.U50**

12 x Ø30 Pizza kapasitesi  
12 x Ø30 Pizza capacity

3 Katlı 62 x 62  
3 Deck 62 x 62

Elektrikli  
Electric

Manuel  
Manual

KOD / CODE						€
Omk.FPZ01.E11.0601.Z50	860x800x370 mm	55 kg	230 / 50-60 V/HZ - 5,1 kW	880x820x520 mm	75 kg	869,39
Omk.FPZ01.E21.0602.U50	860x800x640 mm	99 kg	400 / 50-60 V/HZ - 10,2 kW	880x820x790 mm	119 kg	1.700,78
Omk.FPZ01.E31.0603.U50	860x800x940 mm	140 kg	400 / 50-60 V/HZ - 15,3 kW	880x820x1090 mm	160 kg	2.280,48



**Omk.FPZ01.E11.0701.Z50**

4 x Ø35 Pizza kapasitesi  
4 x Ø35 Pizza capacity

1 Katlı 72 x 72  
1 Deck 72 x 72

Elektrikli  
Electric

Manuel  
Manual



**Omk.FPZ01.E21.0702.U50**

8 x Ø35 Pizza kapasitesi  
8 x Ø35 Pizza capacity

2 Katlı 72 x 72  
2 Deck 72 x 72

Elektrikli  
Electric

Manuel  
Manual



**Omk.FPZ01.E31.0703.U50**

12 x Ø35 Pizza kapasitesi  
12 x Ø35 Pizza capacity

3 Katlı 72 x 72  
3 Deck 72 x 72

Elektrikli  
Electric

Manuel  
Manual

KOD / CODE						€
Omk.FPZ01.E11.0701.Z50	860x900x425 mm	110 kg	230 / 50-60 V/HZ - 5,1 kW	880x920x575 mm	128 kg	1.099,28
Omk.FPZ01.E21.0702.U50	860x900x715 mm	155 kg	400 / 50-60 V/HZ - 10,2 kW	880x920x865 mm	173 kg	2.105,50
Omk.FPZ01.E31.0703.U50	860x900x1050 mm	196 kg	400 / 50-60 V/HZ - 15,3 kW	880x920x1200 mm	214 kg	2.823,98



**TR**

İhtiyaç duyduğunuz işlevsel ve ergonomik çözümler için mutfakların yeni yardımcısı, Omake Kumpir Fırınları.

**EN**

When you need functional and ergonomic solution for potato baking Omake Baked Potato Oven line is your new partner in kitchen.



**TR**



- Elektrikli veya gazlı modeller
- 2 ve 3 çekmece seçeneği
- Paslanmaz çelik çekmece ızgarası
- Çift cidarlı izolasyonlu gövde
- Isıya dayanıklı çekmece kulpları
- Gazlı modeller için piezo çakmak ile ateşleme
- Her çekmece için ayrı paslanmaz çelik rezistans
- Farklı sıcaklık ayarında çalıştırma
- Seri pişirmelerde yüksek performans
- Gösterge ve sinyal lambaları
- Elektrostatik boyalı çelik üst gövde
- Paslanmaz çelik alt gövde

**EN**







- Electric or gas operated options
- 2 and 3 drawer options
- Stainless steel drawer grill
- Double skin insulated body
- Heat resistant drawer handles
- Piezo ignition for gas models
- Separate stainless steel heaters for each drawer for electrical models
- Operation with desired heating temperature
- High performance during dynamic operation
- Power ON and Ready-to-Cook indicators
- Electrostatic painted steel top body
- Stainless steel frame body

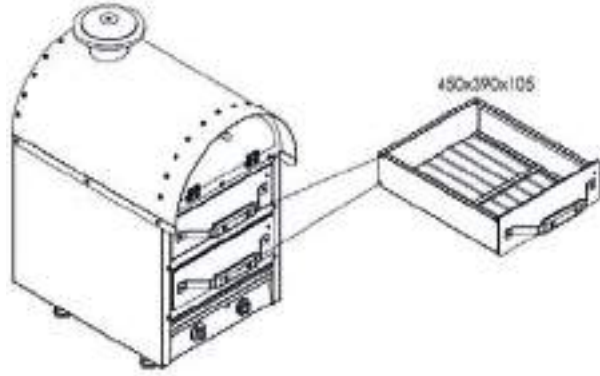

**Omk.FKM03.E21.0002.Z5F**



-  2 Katlı  
2 Deck
-  Elektrik  
Electric
-  Manuel  
Manual









KOD / CODE						
Omk.FKM03.E21.0002.Z5F	485x665x950 mm	56,5 kg	230 / 50-60 V/HZ - 3 kW	790x580x1110 mm	69,5 kg	846,68

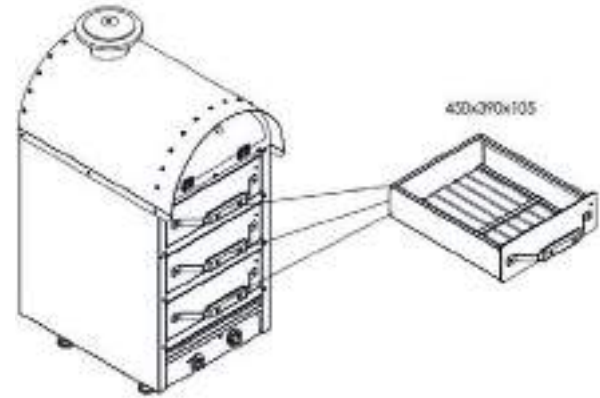

**Omk.FKM03.E31.0003.Z50**



-  3 Katlı  
3 Deck
-  Elektrik  
Electric
-  Manuel  
Manual



KOD / CODE						
Omk.FKM03.E31.0003.Z50	485x665x1120 mm	70,5 kg	230 / 50-60 V/HZ - 4,5kW	800x575x1320 mm	83,5 kg	1.117,57



**Omk.FKM03.N21.0002.000**

-  2 Katlı  
2 Deck
-  Gaz  
Gas
-  Manuel  
Manual

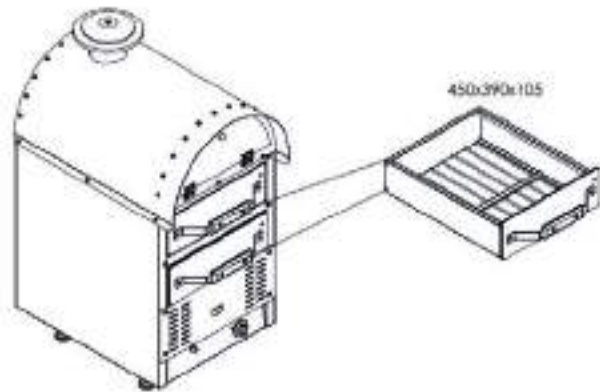

KOD / CODE						
Omk.FKM03.N21.0002.000	485x680x1060 mm	64,0 kg	NG / 21 mbar / 5,8 kW	800x575x1200	76,5 kg	882,25



# EL YIKAMA HAND WASHING



**AYAKTAN KUMANDALI EL YIKAMALAR**  
FOOD OPERATED HAND WASHES



**DİZDEN KUMANDALI EL YIKAMALAR**  
KNEE OPERATED HAND WASHES



**TR**

İhtiyaç duyduğunuz işlevsel ve ergonomik çözümler için mutfakların yeni yardımcısı.

**EN**

The functional and ergonomic you need  
The new assistant of kitchens for solutions.

Sifon Ölçüsü : 1"1/2  
Siphon Diameter : 1"1/2

Köşeli Kenar  
Cornered Edge

**TR**

- AISI-304 Paslanmaz Çelik
- Polisajlanmış yüzey
- 1" 1/2 Sifon ölçüsü
- Köşeli kenar

**EN**

- AISI-304 Stainless steel
- Electropolished material
- 1" 1/2 Siphon diameter
- Cornered edge

## DİZDEN KUMANDALI EL YIKAMALAR KNEE OPERATED HAND WASHES

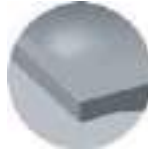

**KÖŞELİ KENAR**  
CORNERED EDGE



**SİFON ÖLÇÜSÜ : 1"1/2**  
SIPHON DIAMETER : 1"1/2

KOD / CODE		SİFON YER / SIPHON PLACE	SİFON TİPİ / SIPHON TYPE		€
Ati.EYK02.030.3512.P03	390x360x210 mm	 Orta / Center	1"1/2	500x460x280 mm	232,47

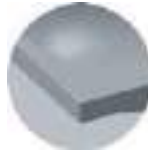

**KÖŞELİ KENAR**  
CORNERED EDGE



**SİFON ÖLÇÜSÜ : 1"1/2**  
SIPHON DIAMETER : 1"1/2

KOD / CODE		SİFON YER / SIPHON PLACE	SİFON TİPİ / SIPHON TYPE		€
Ati.EYK02.038.0012.P03	450x460x210 mm	 Orta / Center	1"1/2	470x490x270 mm	232,71



**KÖŞELİ KENAR**  
CORNERED EDGE



**SİFON ÖLÇÜSÜ : 1"1/2**  
SIPHON DIAMETER : 1"1/2

KOD / CODE		SİFON YER / SIPHON PLACE	SİFON TİPİ / SIPHON TYPE		€
Ati.EYK02.038.0112.P03	490x490x210 mm	 Orta / Center	1"1/2	500x580x330 mm	238,35

## По вопросам продаж и поддержки обращайтесь:

Алматы (727)345-47-04  
Ангарск (3955)60-70-56  
Архангельск (8182)63-90-72  
Астрахань (8512)99-46-04  
Барнаул (3852)73-04-60  
Белгород (4722)40-23-64  
Благовещенск (4162)22-76-07  
Брянск (4832)59-03-52  
Владивосток (423)249-28-31  
Владикавказ (8672)28-90-48  
Владимир (4922)49-43-18  
Волгоград (844)278-03-48  
Вологда (8172)26-41-59  
Воронеж (473)204-51-73  
Екатеринбург (343)384-55-89

Иваново (4932)77-34-06  
Ижевск (3412)26-03-58  
Иркутск (395)279-98-46  
Казань (843)206-01-48  
Калининград (4012)72-03-81  
Калуга (4842)92-23-67  
Кемерово (3842)65-04-62  
Киров (8332)68-02-04  
Коломна (4966)23-41-49  
Кострома (4942)77-07-48  
Краснодар (861)203-40-90  
Красноярск (391)204-63-61  
Курск (4712)77-13-04  
Курган (3522)50-90-47  
Липецк (4742)52-20-81

Магнитогорск (3519)55-03-13  
Москва (495)268-04-70  
Мурманск (8152)59-64-93  
Набережные Челны (8552)20-53-41  
Нижний Новгород (831)429-08-12  
Новокузнецк (3843)20-46-81  
Ноябрьск (3496)41-32-12  
Новосибирск (383)227-86-73  
Омск (3812)21-46-40  
Орел (4862)44-53-42  
Оренбург (3532)37-68-04  
Пенза (8412)22-31-16  
Петрозаводск (8142)55-98-37  
Псков (8112)59-10-37  
Пермь (342)205-81-47

Ростов-на-Дону (863)308-18-15  
Рязань (4912)46-61-64  
Самара (846)206-03-16  
Санкт-Петербург (812)309-46-40  
Саратов (845)249-38-78  
Севастополь (8692)22-31-93  
Саранск (8342)22-96-24  
Симферополь (3652)67-13-56  
Смоленск (4812)29-41-54  
Сочи (862)225-72-31  
Ставрополь (8652)20-65-13  
Сургут (3462)77-98-35  
Сыктывкар (8212)25-95-17  
Тамбов (4752)50-40-97  
Тверь (4822)63-31-35

Тольятти (8482)63-91-07  
Томск (3822)98-41-53  
Тула (4872)33-79-87  
Тюмень (3452)66-21-18  
Ульяновск (8422)24-23-59  
Улан-Удэ (3012)59-97-51  
Уфа (347)229-48-12  
Хабаровск (4212)92-98-04  
Чебоксары (8352)28-53-07  
Челябинск (351)202-03-61  
Череповец (8202)49-02-64  
Чита (3022)38-34-83  
Якутск (4112)23-90-97  
Ярославль (4852)69-52-93

Россия +7(495)268-04-70

Казахстан +7(727)345-47-04

Беларусь +375-257-127-884

Узбекистан +998(71)205-18-59

Киргизия +996(312)96-26-47

эл.почта: [oe\\_k@nt-rt.ru](mailto:oe_k@nt-rt.ru) || сайт: <https://omake.nt-rt.ru>